

**CONVEX 3480-Compatible Cartridge  
Tape Drive Service Guide**

Order No. DHW-062

---

First Edition, Rev. 2  
September 1991

**CONVEX Computer Corporation**  
Richardson, Texas USA

*CONVEX 3480-Compatible Cartridge  
Tape Drive Service Guide  
Order No. DHW-062  
First Edition, Rev. 2*

Copyright 1990, 1991 CONVEX Computer Corporation  
All rights reserved.

This document is copyrighted. All rights reserved. This document may not, in whole or part, be copied, duplicated, reproduced, translated, electronically stored or reduced to machine readable form without prior written consent from CONVEX Computer Corporation (CONVEX).

Although the material contained herein has been carefully reviewed, CONVEX does not warrant it to be free of errors or omissions. CONVEX reserves the right to make corrections, updates, revisions, or changes to the information contained herein. CONVEX does not warrant the material described herein to be free of patent infringement.

UNLESS PROVIDED OTHERWISE IN WRITING WITH CONVEX COMPUTER CORPORATION (CONVEX), THE EQUIPMENT DESCRIBED HEREIN IS PROVIDED "AS IS" WITHOUT WARRANTY OF ANY KIND, EITHER EXPRESSED OR IMPLIED, INCLUDING, BUT NOT LIMITED TO, THE IMPLIED WARRANTIES OF MERCHANTABILITY AND FITNESS FOR A PARTICULAR PURPOSE. SOME STATES DO NOT ALLOW THE EXCLUSION OF IMPLIED WARRANTIES. THE ABOVE EXCLUSION MAY NOT BE APPLICABLE TO ALL PURCHASERS BECAUSE WARRANTY RIGHTS CAN VARY FROM STATE TO STATE. IN NO EVENT WILL CONVEX BE LIABLE TO ANYONE FOR SPECIAL, COLLATERAL, INCIDENTAL, OR CONSEQUENTIAL DAMAGES, INCLUDING ANY LOST PROFITS OR LOST SAVINGS, ARISING OUT OF THE USE OR INABILITY TO USE THIS EQUIPMENT. CONVEX WILL NOT BE LIABLE EVEN IF IT HAS BEEN NOTIFIED OF THE POSSIBILITY OF SUCH DAMAGE BY THE PURCHASER OR ANY THIRD PARTY.

CONVEX and the CONVEX logo ("C") are registered trademarks of CONVEX Computer Corporation  
C1, C120, C201, C202, C210, C220, C230, and C240 are trademarks of CONVEX Computer Corporation  
C100 Series and C200 Series are trademarks of CONVEX Computer Corporation  
ConvexOS is a trademark of CONVEX Computer Corporation  
Fujitsu is a trademark of Fujitsu Limited  
Ciprico and Rimfire are registered trademarks of Ciprico Incorporated

Printed in the United States of America

**Revision Sheet**  
*CONVEX 3480-Compatible Cartridge  
 Tape Drive Service Guide*

Edition	Document	Date	Description
First Edition, Rev. 2	081-006730-002	September 1991	Deleted Bill of Material information. Removed Appendix B, "Reporting Problems." Added Appendix B, "ACL Upgrade Procedures," with operation and installation information on the auto-cartridge loader/stacker. Added Appendix C, "Auto-Cartridge Loader/Stacker" with information on how to install the ACL onto existing cartridge tape systems. Updated references to vendor documentation.
First Edition, Rev.1	081-006730-001	September 1990	
First	081-006730-000	June 1990	

### FCC NOTICE

Warning: This equipment generates, uses, and can radiate radio frequency energy. And, if not installed and used in strict accordance with the instructions manual, it may cause harmful interference to radio communications.

This equipment has been tested and found to comply with the limits for a Class A digital device, pursuant to Part 15 of FCC Rules. These limits are designed to provide reasonable protection against harmful interference when the equipment is operated in a commercial environment.

When this equipment is operated in a residential area, it is likely to cause interference. In this case, the interference must be corrected at the operator's expense.

Do not connect external equipment to the utility outlets in CONVEX equipment cabinets. Unauthorized connection voids all agencies' emissions certifications.

# Table of Contents

---

## 1 Description and Specifications

1.1 Overview .....	1-1
1.1.1 3480-Compatible Cartridge Tape Drive Overview .....	1-3
1.1.2 3480-Compatible Formatter Overview .....	1-4
1.2 Cartridge Tape Drive Specifications .....	1-6
1.3 3480-Compatible Formatter Specifications .....	1-7

## 2 Unpacking and Installation

2.1 Overview .....	2-1
2.2 Unpacking and Inspection .....	2-1
2.2.1 Electrostatic Discharge Damage .....	2-1
2.2.2 Inspection for Damage .....	2-2
2.3 Installation into an Existing Expansion Cabinet .....	2-3
2.3.1 Expansion Cabinet Configuration Requirements .....	2-3
2.3.2 Unpacking .....	2-3
2.3.3 Damage Claims .....	2-3
2.3.4 Installation .....	2-4
2.3.4.1 Installation of the Cartridge Tape Drive and Power Supply .....	2-8
2.3.4.2 Formatter Power Supply Voltage Jumper Check .....	2-17
2.3.4.3 Installation of the Formatter .....	2-19
2.4 Installation of Expansion Cabinet Containing a Cartridge Tape System .....	2-28

## 3 Integration and Test

3.1 Overview .....	3-1
3.2 Software Integration .....	3-1
3.3 Testing the 3480-Compatible Cartridge Tape System .....	3-3
3.4 3480-Compatible Cartridge Tape Internal Tests .....	3-3
3.5 3480-Compatible Formatter Internal Tests .....	3-4

## 4 Maintenance Procedures and IPB

4.1 Overview .....	4-1
4.2 Cartridge Tape Drive Preventative Maintenance .....	4-1
4.2.1 Cleaning the Tape Drive .....	4-1
4.2.2 Filter Maintenance .....	4-2
4.3 Cartridge Tape Drive Maintenance Procedures .....	4-2
4.3.1 Tape Drive Unit Removal and Replacement .....	4-2
4.3.1.1 Removal .....	4-2
4.3.1.2 Replacement .....	4-4
4.3.2 Power Supply Removal and Replacement .....	4-5
4.3.2.1 Removal .....	4-5
4.3.2.2 Replacement .....	4-6
4.3.3 Air Filter Removal/Replacement .....	4-6
4.3.4 Vane Pump Filter Removal/Replacement .....	4-6
4.3.5 CR Board Removal/Replacement .....	4-6
4.3.6 OP Panel Board Removal/Replacement .....	4-6
4.4 Formatter Maintenance Procedures .....	4-7
4.4.1 Formatter Unit Removal/Replacement .....	4-7
4.4.1.1 Removal .....	4-7
4.4.1.2 Replacement .....	4-8

4.4.2 PC Board Removal/Replacement .....	4-8
4.4.3 OP Panel Assembly Removal/Replacement .....	4-8
4.4.4 Fan Removal/Replacement .....	4-8
4.4.5 Power Supply Removal/Replacement .....	4-8
4.5 3480-Compatible Cartridge Tape Drive Part List .....	4-9
4.6 3480-Compatible Formatter Parts List .....	4-10
4.7 3480-Compatible Cartridge Tape System Cable List and IPB .....	4-10

## Appendixes

### A Fujitsu 2481B Tape Subsystem Configurator

### B Automatic Cartridge Loader (ACL)

B.1 Overview .....	B-1
--------------------	-----

### C ACL Upgrade Procedures

C.1 Installation onto Existing Cartridge Tape Drive .....	C-1
C.1.1 Preinstallation .....	C-3
C.1.2 Removal of Existing Devices .....	C-7
C.1.2.1 Formatter Removal .....	C-7
C.1.2.2 Tape Drive Removal .....	C-7
C.1.3 ACL Installation .....	C-7
C.1.4 Replacement of Existing Devices .....	C-8
C.1.5 Postinstallation .....	C-13
C.2 Part Number List .....	C-13

## List of Tables

1-1 3480-Compatible Cartridge Tape Specifications .....	1-6
1-2 3480-Compatible Formatter Specifications .....	1-7
2-1 Static Charge Levels and Relative Humidity .....	2-1
2-2 Components Susceptibility to ESD Damage .....	2-2
2-3 SW1 Jumper Switch Settings on the DI Card .....	2-21
2-4 SW2 Jumper Switch Settings on the DI Card .....	2-21
4-1 3480-Compatible Cartridge Tape Drive Parts List .....	4-9
4-2 3480-Compatible Formatter Parts List .....	4-10
4-3 3480-Compatible Cartridge Tape System Cable List .....	4-11
C-1 ACL Parts List .....	C-13
C-2 Cabinet Door Parts List .....	C-13
C-3 Extender Bracket Kit Parts List .....	C-14

## List of Figures

1-1 CONVEX 3480-Compatible Cartridge Tape System Block Diagram .....	1-2
1-2 3480-Compatible Cartridge Tape Drive .....	1-4
1-3 3480-Compatible Formatter .....	1-5
2-1 Front Panel Power Control Switch .....	2-5

2-2	Expansion Cabinet Power Controller Front Panel .....	2-6
2-3	Expansion Cabinet Stabilizer Bars .....	2-7
2-4	Cable Shielding Clamp for First Tape Drive .....	2-9
2-5	Cable Shielding Clamp for Intermediate Tape Drives .....	2-10
2-6	Cable Shielding Clamp for Last Tape Drive .....	2-11
2-7	Power Supply to Tape Drive Cable .....	2-12
2-8	Tape Drive Shield Bracket .....	2-13
2-9	Tape-Drive-to-Tape-Drive Cabling .....	2-15
2-10	Expansion Cabinet Power Strip and AC Power Cables .....	2-16
2-11	Formatter Voltage Jumper Location and Settings .....	2-18
2-12	DI Card Dip Switches .....	2-20
2-13	Formatter Rear Mounting Brackets .....	2-22
2-14	Formatter-to-Tape Drive Cabling .....	2-24
2-15	Formatter-to-Formatter Cabling .....	2-26
2-16	PCI-to-PCO Cabling .....	2-27
3-1	Example <i>/ioconfig</i> File .....	3-2
4-1	Expansion Cabinet Stabilizer Bars .....	4-3
4-2	3480-Compatible Cartridge Tape System Cable IPB #1 .....	4-12
4-3	3480-Compatible Cartridge Tape System Cable IPB #2 .....	4-13
C-1	Required Cabinet Arrangement for ACL Use .....	C-2
C-2	C200 Series Front Panel Power Control Switch .....	C-4
C-3	EXP-106 Expansion Cabinet Power Controller Front Panel .....	C-5
C-4	Expansion Cabinet Stabilizer Bars .....	C-6
C-5	Extender Bracket Installation .....	C-8
C-6	Tape Drive Installation Onto Bracket .....	C-9
C-7	Tape Drive Apron .....	C-11
C-8	Cabinet with ACL Installed .....	C-12

**THIS PAGE INTENTIONALLY LEFT BLANK**

# Preface

## Purpose and Audience

The *CONVEX 3480-Compatible Cartridge Tape Service Guide* provides a general overview of the CONVEX 3480-compatible cartridge tape system and related hardware and shows how to:

- Install the 3480-compatible cartridge tape system and related hardware
- Integrate the 3480-compatible cartridge tape system into the CONVEX Operating System (ConvexOS)
- Test the 3480-compatible cartridge tape system and related hardware
- Remove and replace the 3480-compatible cartridge tape system and related hardware
- Install, operate, remove and replace the Automatic Cartridge Loader (ACL)

## Audience

This document is intended for:

- CONVEX Customer Support Engineers and CONVEX manufacturing personnel
- Customers who need to install a 3480-compatible cartridge tape system and related hardware

## Organization

The document consists of the following:

- **Chapter 1. Description and Specifications**—Describes the 3480-compatible cartridge tape system and related hardware at the block diagram level. Defines and lists the electromechanical and environmental specifications.
- **Chapter 2. Unpacking and Installation**—Provides guidelines on how to unpack and install the 3480-compatible cartridge tape and related hardware.
- **Chapter 3. Integration and Test**—Explains how to integrate the 3480-compatible cartridge tape system into the CONVEX operating system. Explains how to test the 3480-compatible cartridge tape drive and 3480-compatible formatter.
- **Chapter 4. Maintenance Procedures and IPB**—Provides removal and replacement instructions for the 3480-compatible cartridge tape system and related hardware. Provides an Illustrated Parts Breakdown (IPB) for the cables of the 3480-compatible cartridge tape system.
- **Appendix A. Fujitsu 2481B Tape Subsystem Configurator** —Contains a copy of the Fujitsu 2481B Tape Subsystem Configurator document.
- **Appendix B. Automatic Cartridge Loader (ACL)**—Provides information on the operation and installation of the ACL.
- **Appendix C. ACL Upgrade Procedures**—Describes how to add an ACL to an existing peripheral cabinet.

## Notational Conventions

Notational conventions are systems of characters, symbols, terms, or abbreviated expressions used to express technical facts or quantities as established by this guide. The following notational conventions are used in this document:

- **Boldface** indicates user-entered information for a computer program and should be entered exactly as they appear.
- *Italic* is used for emphasis and also designates file names, program names, directory paths, release tape titles, and titles of publications.

All CONVEX illustrations have an illustration file number at the bottom right-hand corner that is for CONVEX use only.

Examples of typical warnings, cautions and notes as used in CONVEX documents follow:

### WARNING

A warning highlights procedures or information necessary to avoid injury to personnel. A warning immediately precedes the critical information and includes a description of the hazard.

# Chapter 1

## Description and Specifications

### 1.1 Overview

The CONVEX 3480-compatible cartridge tape system is a high-performance 1/2-inch cartridge tape with a 4-inch by 4-inch form factor. The peak data transfer rate is 3 Mbytes/second with a total storage capacity of 200 Mbytes. A single VMEbus SCSI host adapter can control up to 4 formatters. Each formatter can operate up to 4 tape drives. A maximum system configuration with 1 VMEbus SCSI host adapter would include 4 formatters and 16 cartridge tape drives.

**NOTE**

A maximum of 16 CONVEX 3480-compatible cartridge tape drives can be connected to a single VMEbus Input/Output Processor (VIOP).

For performance reasons, customers may elect to limit the number of devices attached to a single host adapter to a maximum of 2 formatters and 4 tape drives.

This chapter describes the general functions and specifications of the CONVEX 3480-compatible cartridge tape system. Figure 1-1 shows a block diagram of the CONVEX 3480-compatible cartridge tape system:

Figure 1-1, CONVEX 3480-Compatible Cartridge Tape System Block Diagram



H062002  
4/6/90

### 1.1.1 3480-Compatible Cartridge Tape Drive Overview

The CONVEX 3480-compatible cartridge tape drive and the CONVEX 3480-compatible formatter form the CONVEX 3480-compatible cartridge tape system. This system was developed to allow compatibility with the ISO-X3B5 standard and other 3480-compatible cartridge tape devices.

The CONVEX 3480-compatible cartridge tape drive has the following features:

- Compatibility with the ISO-X3B5 standard and other 3480-compatible cartridge tape devices
- Peak transfer rate of 3 Mbytes/second synchronously
- 200-Mbyte data cartridge using 18 tracks at 37,871 bpi
- Built-in diagnostic routines
- Two cartridge tape drives with power supplies that will install in a EIA-standard, 19-inch rack mount

**NOTE**

Refer to the *Fujitsu Cartridge Tape Drives CE Manual*, chapter 1, "INTRODUCTION," for more information on the CONVEX 3480-compatible cartridge tape drive.

Figure 1-2 shows a front view of the CONVEX 3480-compatible cartridge tape drive:

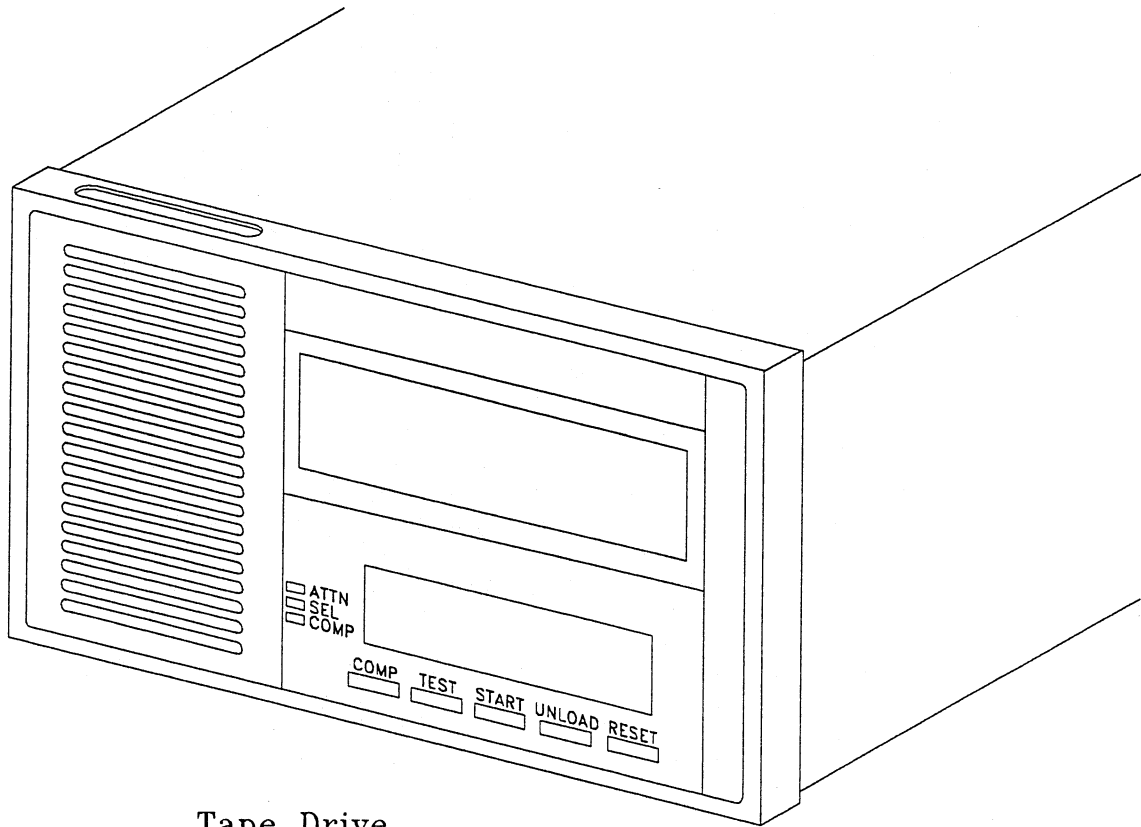
**Figure 1-2, 3480-Compatible Cartridge Tape Drive**Tape Drive  
(Front View)H062005  
3/19/90

### 1.1.2 3480-Compatible Formatter Overview

The CONVEX 3480-compatible cartridge tape system is designed to include four formatters that interface with the CONVEX VMEbus SCSI host adapter installed in the VMEbus chassis. Also, each formatter can control up to four cartridge tape drives.

The CONVEX 3480-compatible formatter has the following features:

- Controls up to four CONVEX 3480-compatible cartridge tape drives
- Reads up to 128-Kbyte data blocks
- 2-Mbyte internal buffer, partitioned among the tape drives
- Peak transfer rates up to 3 Mbytes/second
- Self-diagnostics invoked from the front panel
- Slide-out drawer in EIA-standard, 19-inch rack mount

Figure 1-3 shows a front view of the CONVEX 3480-compatible formatter:

**Figure 1-3, 3480-Compatible Formatter**

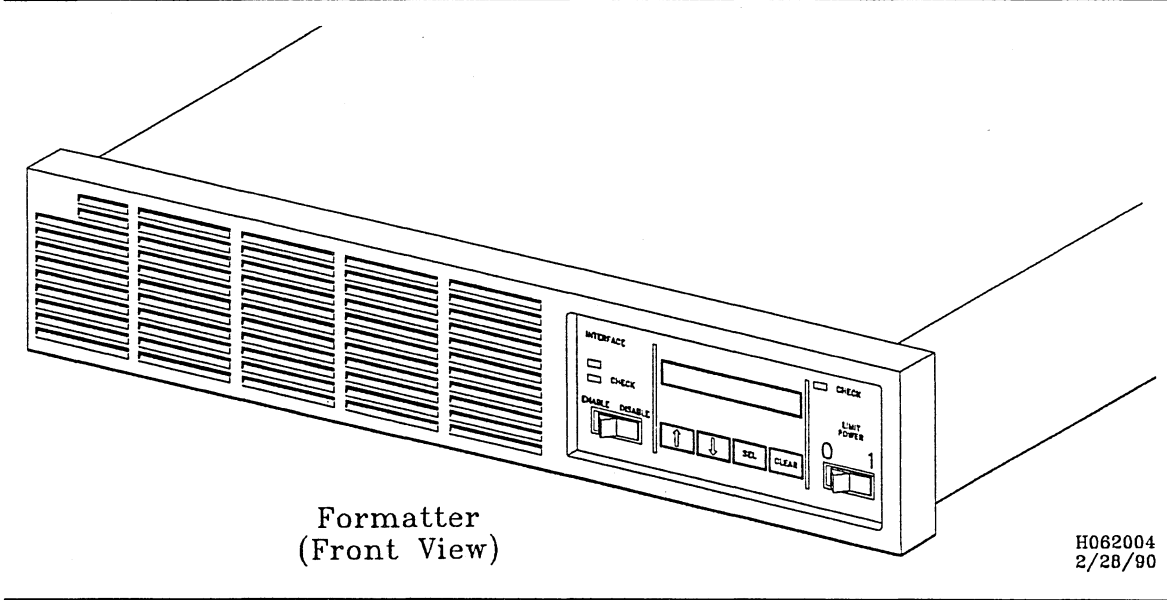

## 1.2 Cartridge Tape Drive Specifications

Table 1-1 lists the operational specifications for the 3480-compatible cartridge tape drive:

**Table 1-1, 3480-Compatible Cartridge Tape Specifications**

Parameter	Value/Comment
Width	8.6 in (218 mm)
Height	5.0 in (127 mm)
Depth	15.0 in (381 mm)
Weight	≥ 27 lb (12 kg)
Voltage Range <sup>1</sup>	+24 VDC +10%, -5% 4.0 Amp +12.0 VDC ±7% 2.0 Amp +5.0 VDC ±5% 5.0 Amp -5.2 VDC ±5% 3.0 Amp
Temperature Range: Operating Non-Operating	41 °F to 104 °F (5 °C to 40 °C) 32 °F to 122 °F (0 °C to 122 °C)
Temperature Change	≥ 59 °F/hr (15 °C/hr)
Humidity Range: Operating Non-Operating	20% to 80% with no condensation 8% to 95% with no condensation
Humidity Change	≥ 20%/hr
Wet Bulb	84.2 °F (29 °C)
Altitude (operating) <sup>2</sup>	6,000 ft (1,800 m)
Noise	≥ 55 dB

<sup>1</sup> Voltages are measured on the cartridge tape drive side of the power supply terminals.

<sup>2</sup> If the altitude of the installation site is greater than 3000 feet (approximately 1000 meters), set the pump use mode to **HI**. Refer to the *Fujitsu Cartridge Tape Drives CE Manual*, chapter 5, "SETTING METHOD," section 5.2.2, "Setting methods," for the procedures to set the pump use mode. Failure to do so will cause damage to equipment.

### 1.3 3480-Compatible Formatter Specifications

Table 1-2 lists the operational specifications for the 3480-compatible cartridge tape formatter:

**Table 1-2, 3480-Compatible Formatter Specifications**

Parameter	Value/Comment
Width	19.0 in (483.0 mm)
Height	3.5 in (88.9 mm)
Depth	27.0 in (685.0 mm)
Weight	49 lb (22 kg)
Voltage Range: Domestic International	100 VAC to 130 VAC 4 Amp 200 VAC to 240 VAC 2 Amp
Temperature Range: Operating Non-Operating	60 ° F to 90 ° F (16 ° C to 40 ° C) 50 ° F to 120 ° F (10 ° C to 49 ° C)
Temperature Change	≥ 59 ° F/hr (15 ° C/hr)
Humidity Range: Operating Non-Operating	20% to 80% with no condensation 0% to 95% with no condensation
Humidity Change	≥ 20%/hr
Wet Bulb	84.2 ° F (29 ° C)
Altitude (operating)	10,000 ft (3,000 m)

**THIS PAGE INTENTIONALLY LEFT BLANK**

# Chapter 2

## Unpacking and Installation

### 2.1 Overview

This chapter discusses unpacking and inspection, identifies major components of the 3480-compatible cartridge tape system assembly, and provides installation procedures.

### 2.2 Unpacking and Inspection

This section gives general guidelines for unpacking and inspecting the 3480-compatible cartridge tape drives, 3480-compatible formatters, and related hardware. Also, this section gives safety and equipment damage precaution information.

#### 2.2.1 Electrostatic Discharge Damage

Typically, Electrostatic Discharge (ESD) damage occurs to electronic circuit boards during handling. Static charges take place when various objects are separated or rubbed together, often creating a high voltage-level charge. If a high voltage-level charge is discharged into electronic computer circuits, the charge damages the electronic components. The main factors that determine a voltage level charge are:

- Types of materials
- Relative humidity
- Rate of change or separation

Table 2-1 lists an approximation of electrostatic charge levels based on various personnel activities and humidity levels:

**Table 2-1, Static Charge Levels and Relative Humidity**

Personnel Activity <sup>1</sup>	Humidity <sup>2</sup> & Charge Levels (Volts <sup>3</sup> )			
	26%	32%	40%	50%
Person walking across linoleum floor	6,150V	5,750V	4,625V	3,700V
Person walking across carpet	18,450V	17,250V	13,875V	11,100V
Person getting up from a plastic chair	24,600V	23,000V	18,500V	14,800V

<sup>1</sup> Source: B. A. Unger, *Electrostatic Discharge Failures of Semiconductor Devices* (Bell Laboratories, 1981).

<sup>2</sup> A high rate of air-flow produces higher static charges than a low air flow rate, for the same relative humidity level.

<sup>3</sup> Some data in this table has been extrapolated.

Table 2-2 lists various components and their susceptibility to static damage:

**Table 2-2, Components Susceptibility to ESD Damage**

Susceptibility Ranges of Various Devices Exposed to Electrostatic Discharge (Human Body Model <sup>1</sup> )	
Device Type	Level of ESD Susceptibility (Volts)
MOSFET	> 10
JFET	> 140
CMOS	> 250
Schottky Diodes, TTL	> 300
Bipolar Transistors	> 380
ECL (For Hybrid use, PCB level)	> 500
SCR	> 680

<sup>1</sup> Source: B. A. Unger, *Electrostatic Discharge Failures of Semiconductor Devices* (Bell Laboratories, 1981).

### 2.2.2 Inspection for Damage

All shipping containers have been specially designed to protect their contents under normal shipping conditions. Carefully inspect each carton for signs of shipping damages as it is unpacked. If damage is found after visual inspection, document the damage with photographs and contact the transport carrier immediately.

## 2.3 Installation into an Existing Expansion Cabinet

The following sections give procedures for installing a 3480-compatible cartridge tape system into an existing CONVEX expansion cabinet.

### 2.3.1 Expansion Cabinet Configuration Requirements

The CONVEX 3480-compatible cartridge tape system can be installed in any CONVEX peripheral expansion cabinet. The following list gives maximum configurations for each style of cabinet:

- One EXP-105 or equivalent high-performance expansion cabinet can contain a maximum of 3 formatters and 12 tape drives.
- One EXP-101, EXP-102, or EXP-302 expansion cabinet can contain a maximum of one formatter and four tape drives.

**NOTE**

For performance reasons, customers may elect to attach only a maximum of two formatters and four tape drives to a single host adapter.

### 2.3.2 Unpacking

The customer's bill of material lists all equipment shipped from CONVEX. It should be used as a checklist to ensure that all equipment has arrived.

The procedure for unpacking the shipping container is as follows:

1. Unpack each item of equipment from its shipping container.
2. Inspect each item of equipment for any sign of shipping damage as it is unpacked.
3. If equipment damage is found, document and proceed to the next section.

**NOTE**

Save all packing material until after operational checkout of the equipment. This enables equipment to be returned safely to CONVEX, if required.

### 2.3.3 Damage Claims

If the 3480-compatible cartridge tape drives, 3480-compatible formatter, or related hardware is damaged, a damage claim must be completed. Damage claims should be completed by the customer and given to the shipping representative. Claim forms are normally obtained from the shipping representative.

### 2.3.4 Installation

This section gives the procedure for installing the 3480-compatible cartridge tape system into an existing expansion cabinet.

#### CAUTION

Shut down system before removing power to the existing expansion cabinet. Failure to do so will cause a system crash and possible loss of data. Refer to the *CONVEX Processor Operation Guide (C100 Series, C200 Series)* for power-down procedures on a CONVEX supercomputer.

#### NOTE

The maximum length for the SCSI host adapter cable to the first formatter in the system is approximately 75 feet (25 meters).

1. Turn the processor's front panel key switch to the **OFF** position. Figure 2-1 shows a typical front panel control switch:

Figure 2-1, Front Panel Power Control Switch

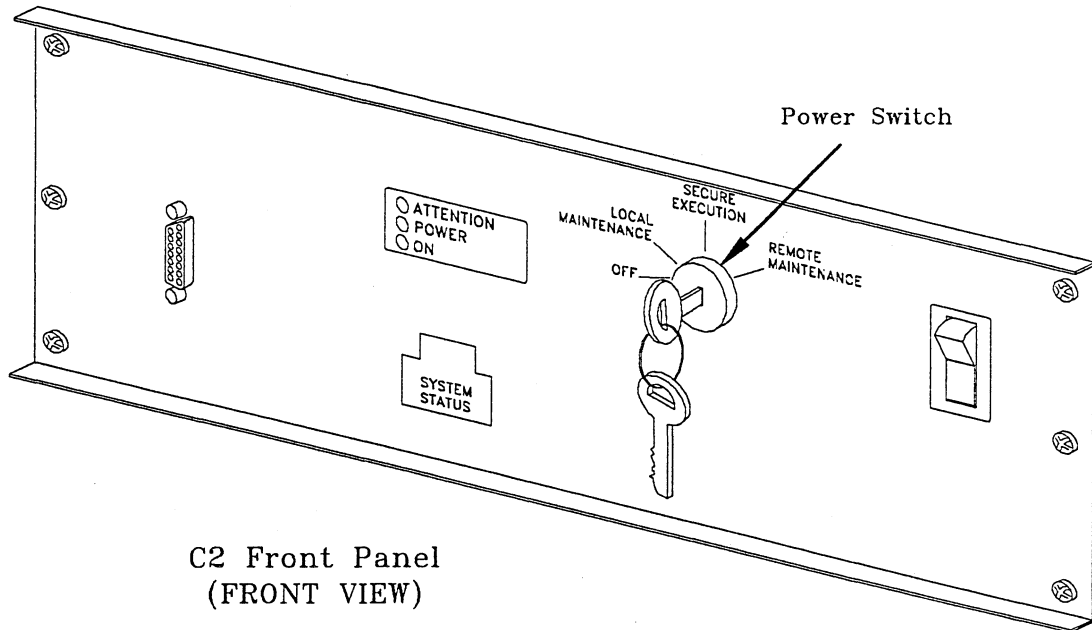
C2 Front Panel  
(FRONT VIEW)AH062014  
9/4/91**CAUTION**

Remove power to the peripheral expansion cabinet before installing or removing equipment. Failure to do so will damage electronic equipment components.

## 2. Remove power to the expansion cabinet.

- To remove power from a CONVEX EXP-101, EXP-102, or EXP-302 expansion cabinet, disconnect the cabinet's AC power cord.
- To remove power from a CONVEX EXP-105 or equivalent high-performance expansion cabinet, set the main power control switch to the **OFF** position. Figure 2-2 shows the EXP-105 or equivalent expansion cabinet's power controller front panel and main power control switch:

Figure 2-2, Expansion Cabinet Power Controller Front Panel

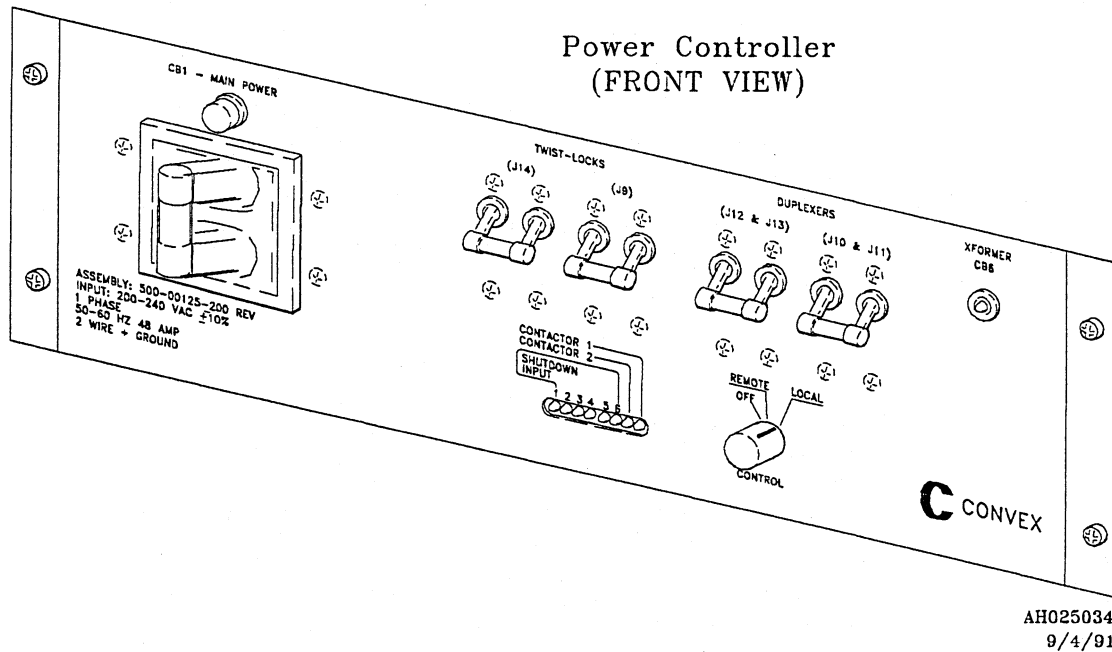
**WARNING**

Expansion cabinet stabilizer bars must be extended before installing a VMEbus chassis or before extending the VMEbus chassis assembly from its expansion cabinet for service. Failure to do so will make the expansion cabinet unstable, increase the possibility of it falling forward, can cause injury to personnel, and will cause damage to equipment.

3. Extend the expansion cabinet stabilizer bars and adjust the feet until they are in firm contact with the floor. Figure 2-3 shows the expansion cabinet stabilizer bars and adjustable feet:

Figure 2-3, Expansion Cabinet Stabilizer Bars

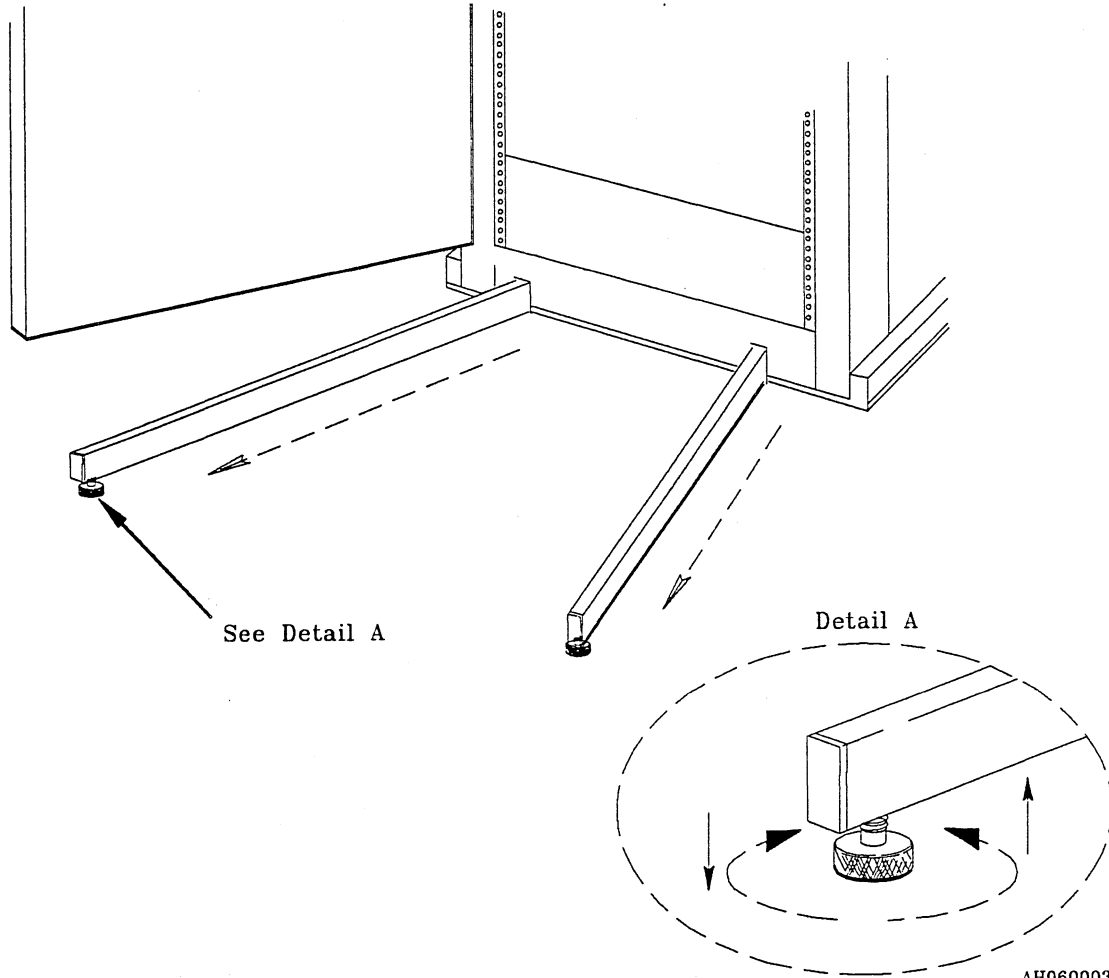

AH060003  
9/4/91

### 2.3.4.1 Installation of the Cartridge Tape Drive and Power Supply

This section gives the procedure for installing a cartridge tape drive.

1. Install the tape drive(s), power supply, and mounting frame.

**NOTE**

Refer to *Fujitsu Cartridge Tape Drives CE Manual*, chapter 3, "INSTALLATION CONDITIONS," section 3.5.1, "Rack Mount Kit Installation," for the procedures to install this equipment.

**CAUTION**

The cable clamp should contact the exposed cable shielding and fit tightly on to the cable. Failure to do so will result in the loss of the Electromagnetic Interference (EMI) shielding and may cause damage to equipment.

2. Install the cables into the cable shielding clamp. The first, intermediate, and last tape drives in a daisy chain have different cable shielding configurations. Figure 2-4 shows how to install the cables into the shielding clamp for the first tape drive in a daisy chain:

Figure 2-4, Cable Shielding Clamp for First Tape Drive

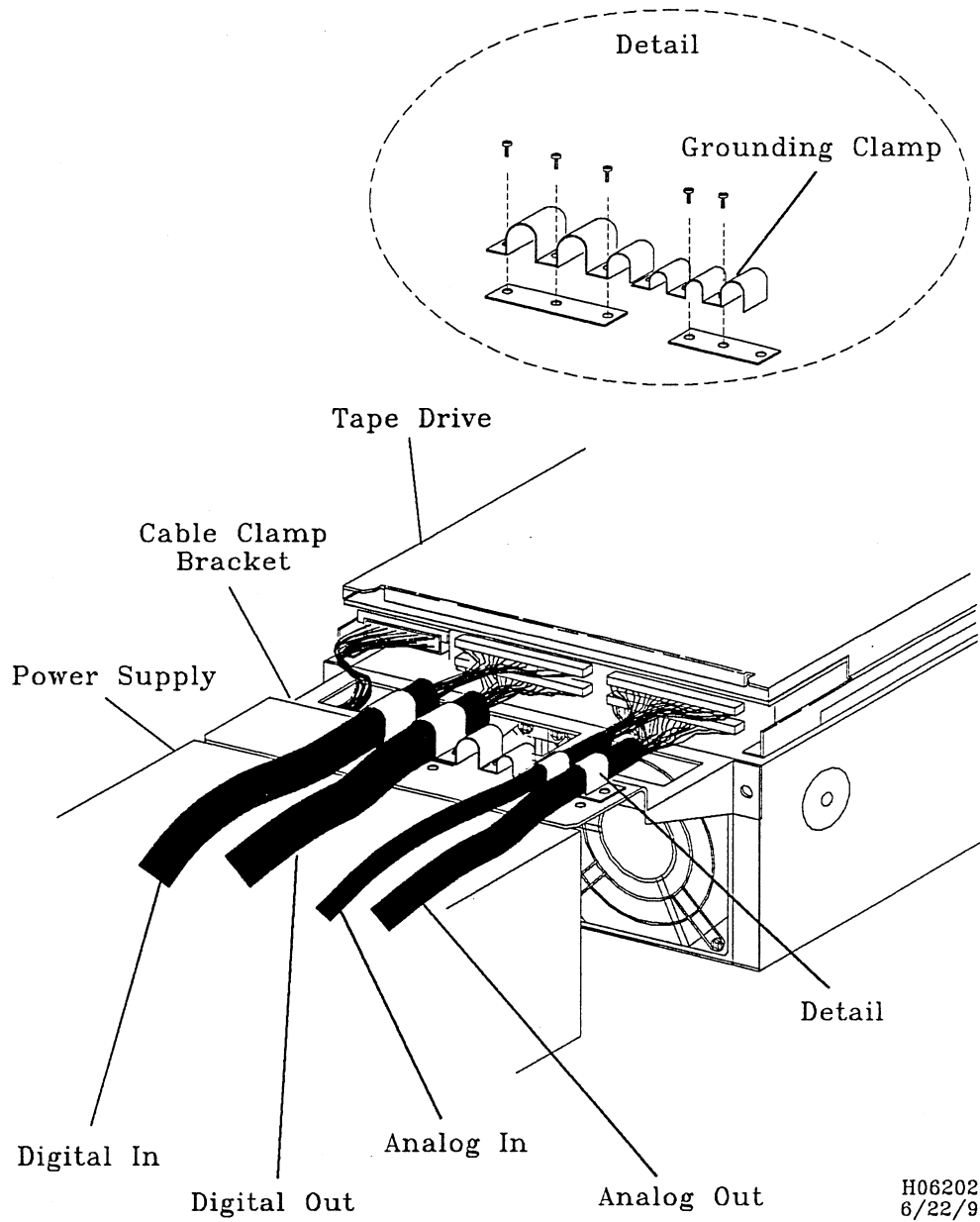

H062023  
6/22/90

Figure 2-5 shows the cable installation into the shielding clamp for tape drives in the middle of a daisy chain:

**Figure 2-5, Cable Shielding Clamp for Intermediate Tape Drives**

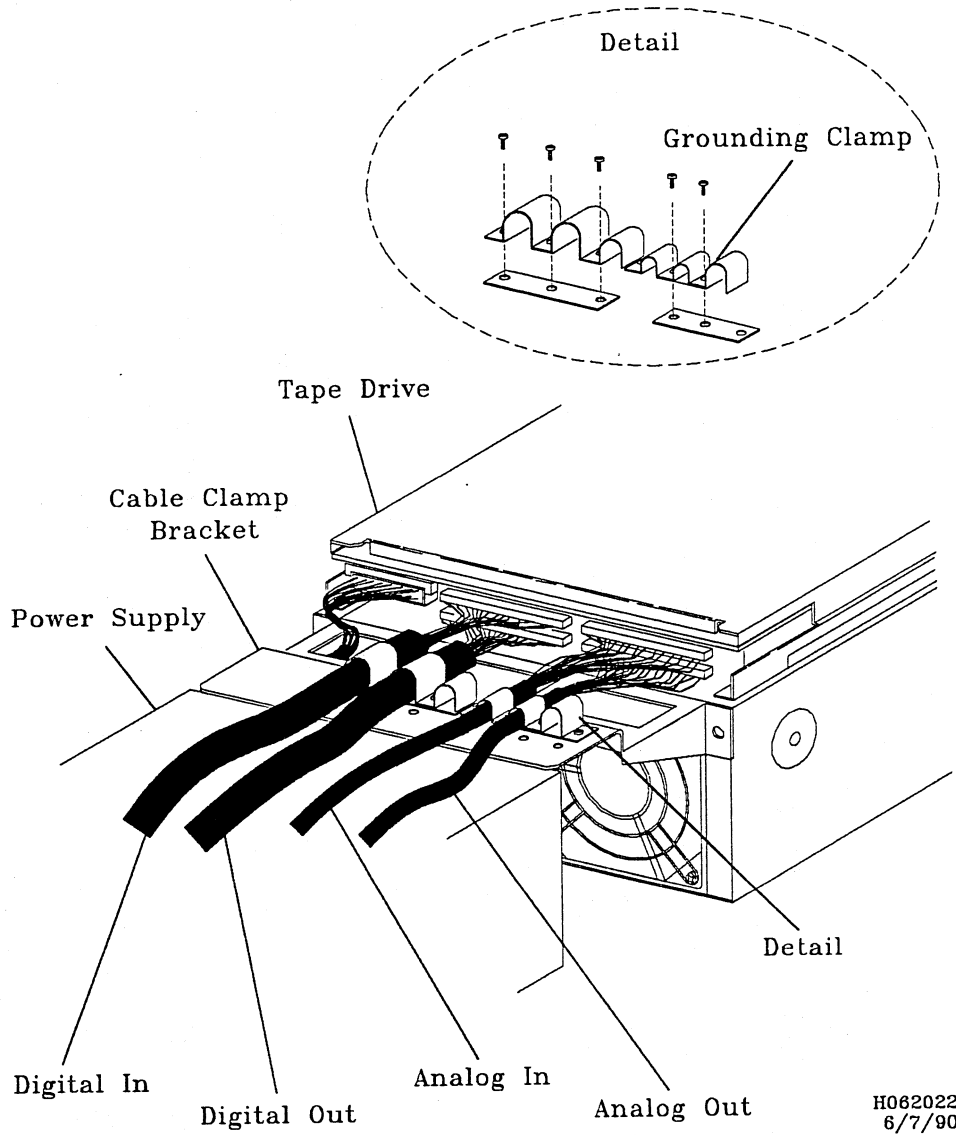

H062022  
6/7/90

Figure 2-6 shows the cable installation into the shielding clamp for tape drives at the end of a daisy chain:

**Figure 2-6, Cable Shielding Clamp for Last Tape Drive**

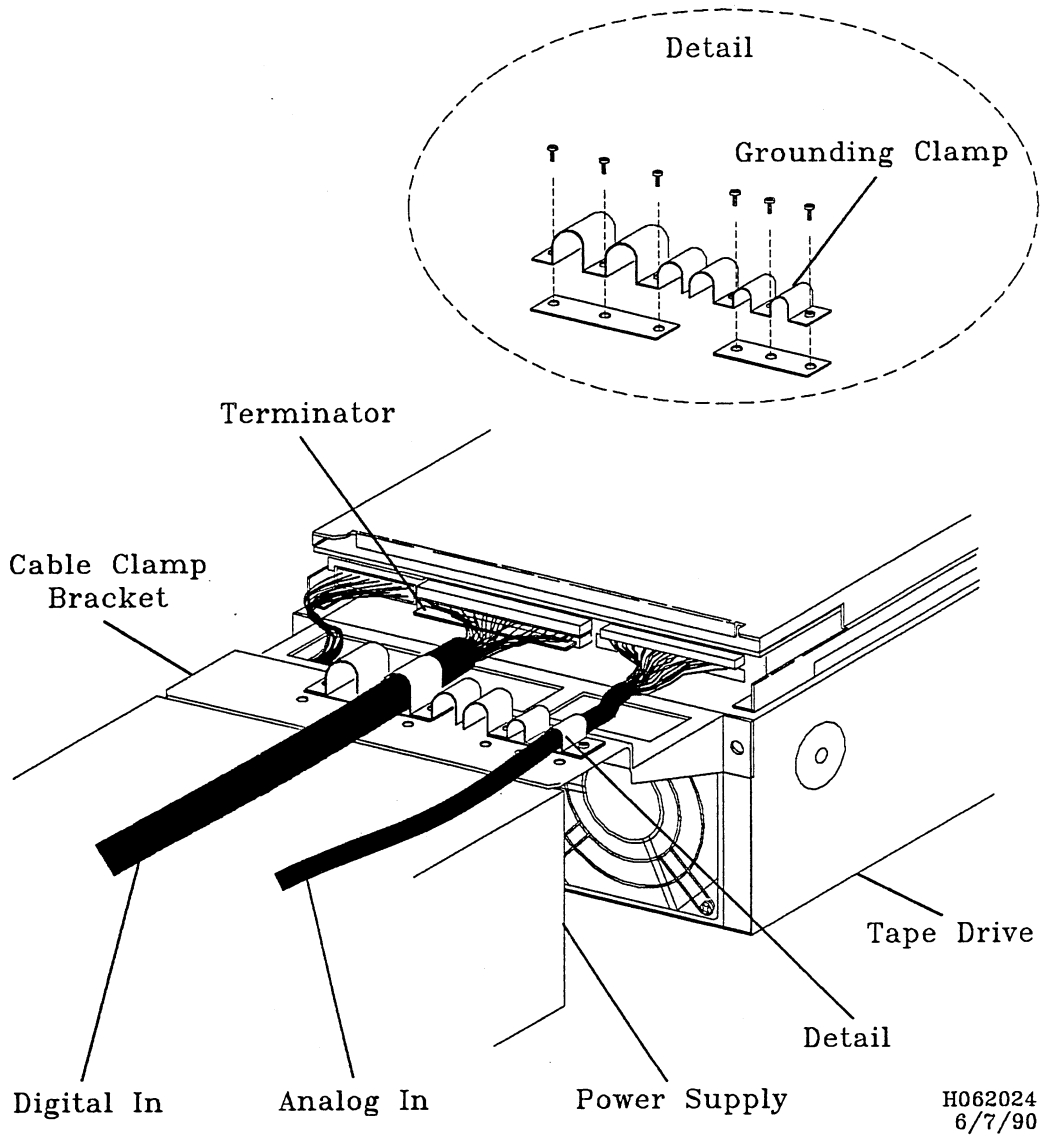

3. Connect the DC power cable to the tape drive. Route the cable through the cable shielding clamp and connect to the power supply. Figure 2-7 shows the DC power cable connected between the power supply and the tape drive:

**Figure 2-7, Power Supply to Tape Drive Cable**

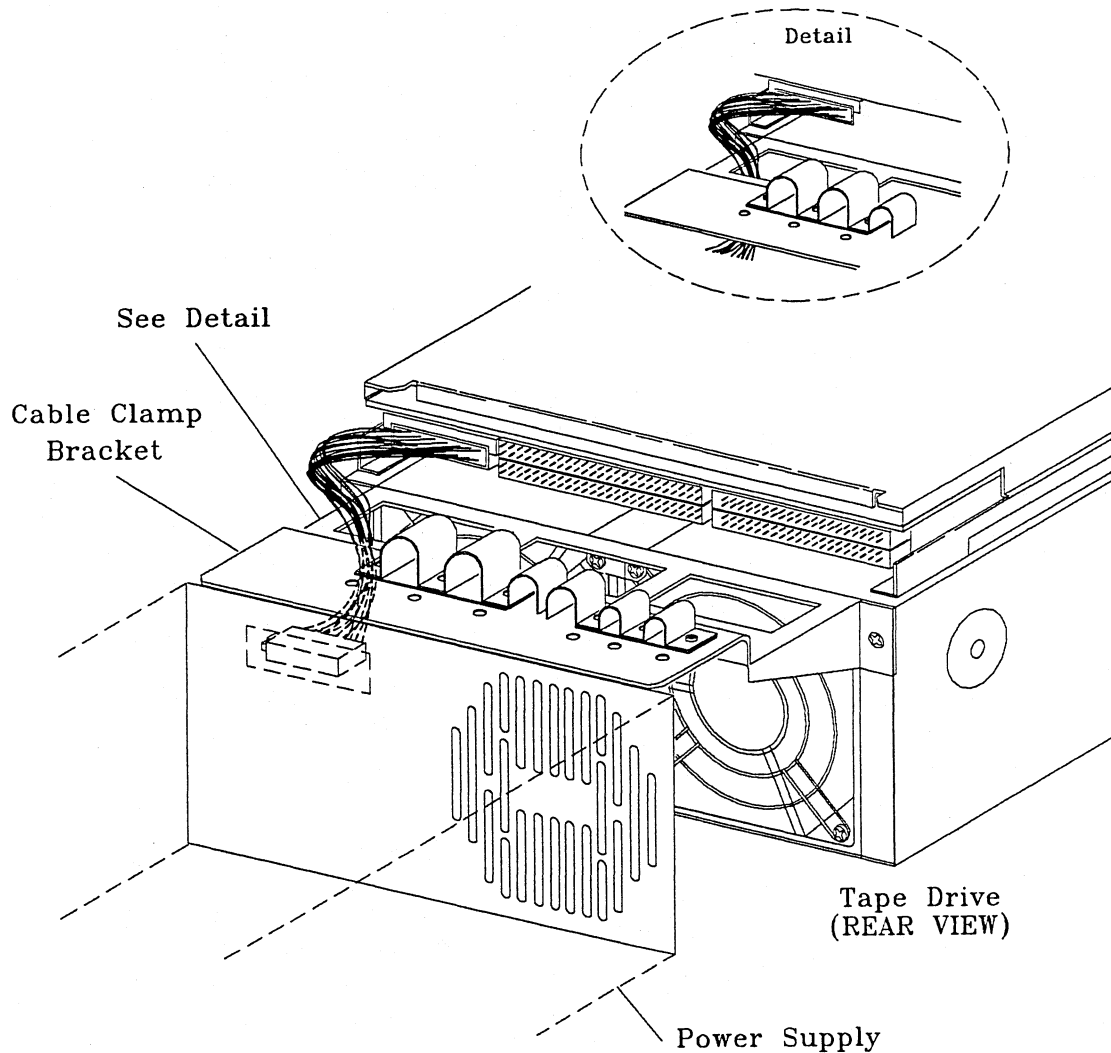

H062011  
6/19/90

4. Install the shield bracket onto the rear of the tape drive and over the cable shield clamp. Install the 2 screws that secure the shield bracket. Figure 2-8 shows the shield bracket in place:

Figure 2-8, Tape Drive Shield Bracket

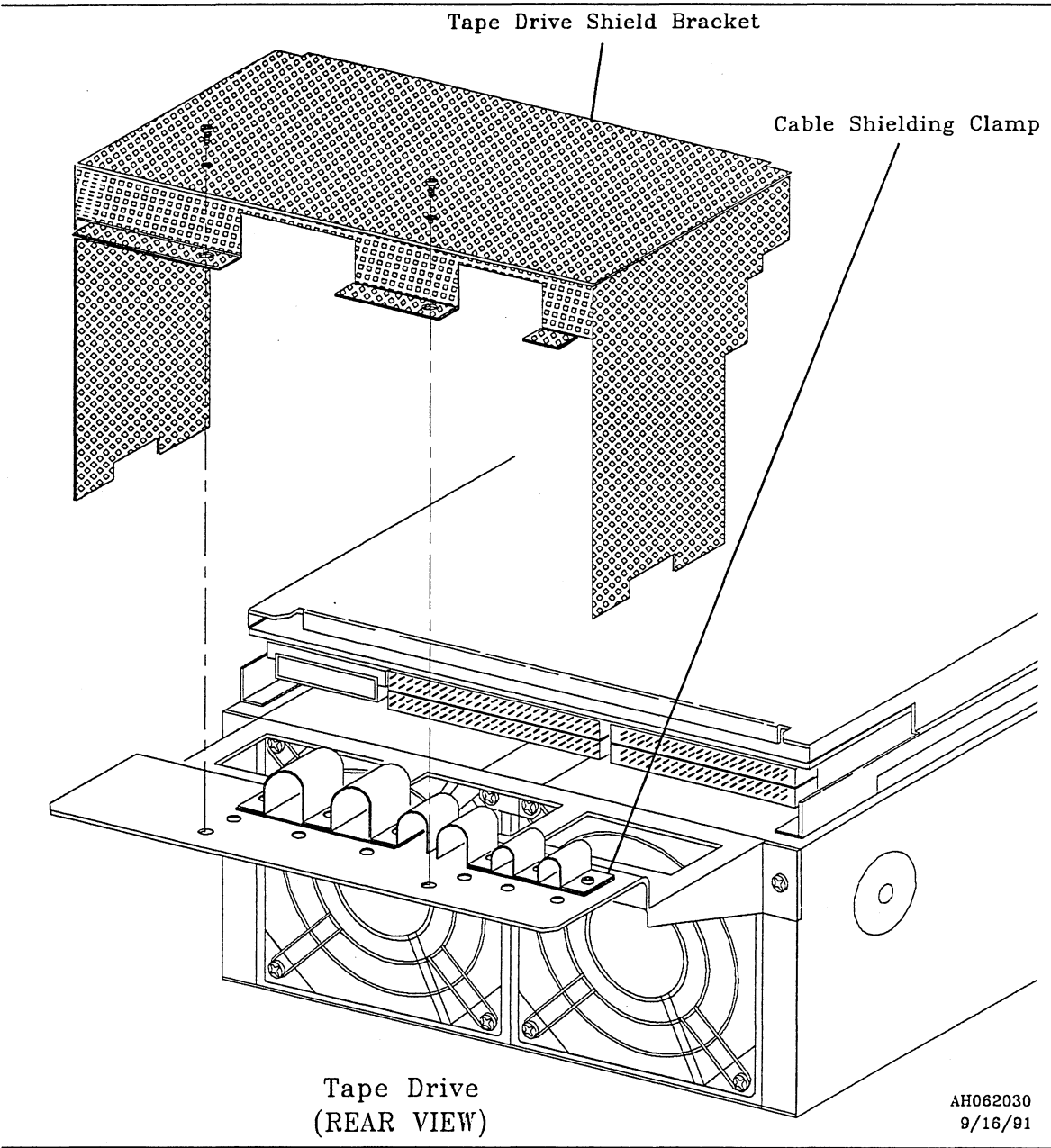

5. Cable the tape drives to the formatter and daisy chain to other drives (if necessary).  
Figure 2-9 shows the cabling of a tape drive to another tape drive:

**NOTE**

Refer to *Fujitsu Cartridge Tape Drives CE Manual*, chapter 3, "INSTALLATION CONDITIONS," section 3.5.2, "Cable connection," for cabling procedures.

Figure 2-9, Tape-Drive-to-Tape-Drive Cabling

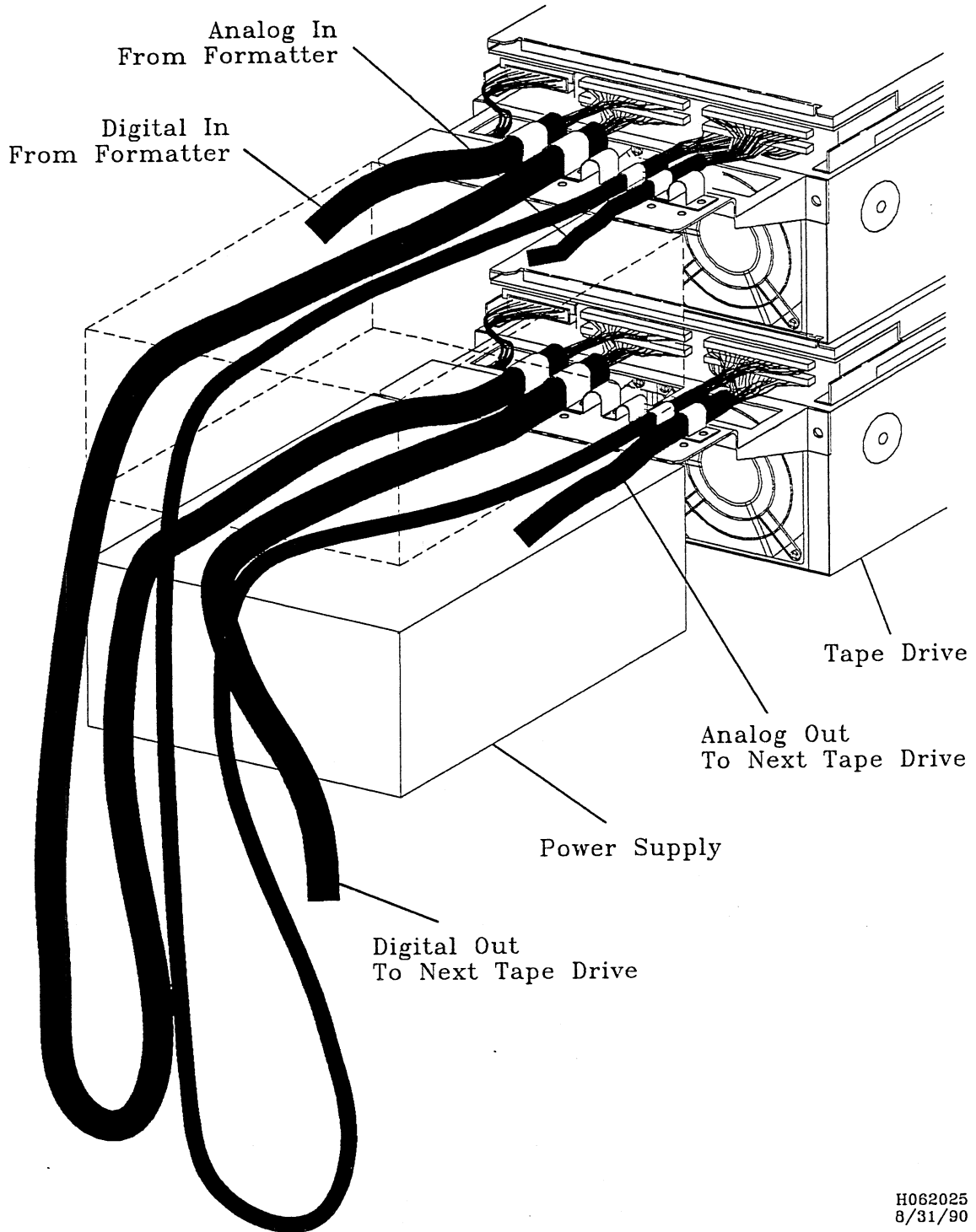

H062025  
8/31/90

6. Connect the AC power cable from the power supply to the expansion cabinet power strip. Figure 2-10 shows the power strips of an EXP-105 or equivalent high-performance expansion cabinet:

**Figure 2-10, Expansion Cabinet Power Strip and AC Power Cables**

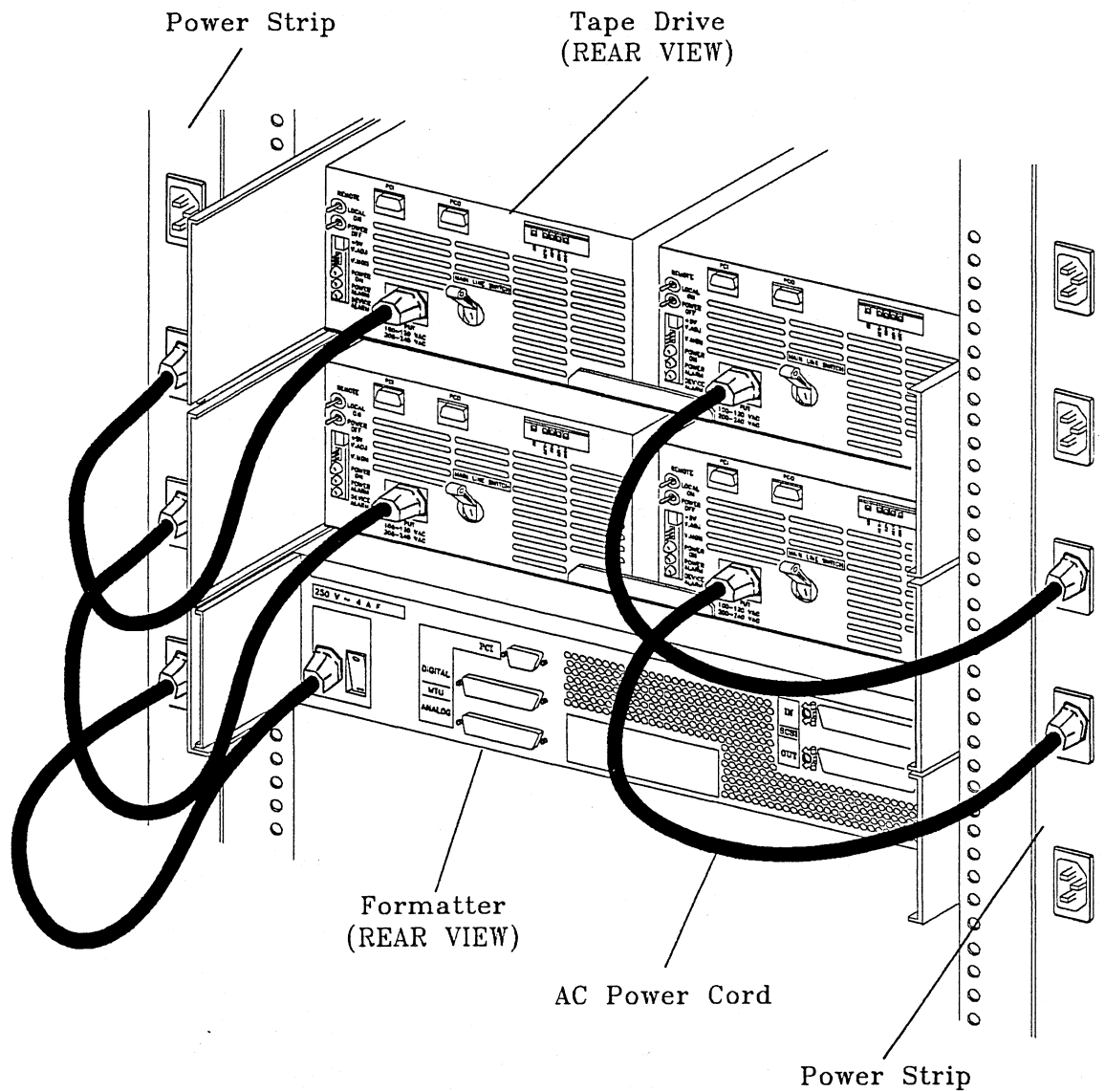

H062010  
4/16/90

**CAUTION**

If the altitude of the installation site is greater than 3000 feet (approximately 1000 meters), set the pump use mode to **HI**. Refer to the *Fujitsu Cartridge Tape Drives CE Manual*, chapter 5, "SETTING METHOD," section 5.2.2, "Setting methods," for the procedures to set the pump use mode. Failure to do so will can damage to equipment and loss of data.

**2.3.4.2 Formatter Power Supply Voltage Jumper Check**

This section gives the procedure to insure that the formatter's internal power supply voltage jumper is set properly.

**CAUTION**

During installation, make sure that the 3480-compatible formatter's internal power supply voltage jumper is set properly and agrees with the label on the rear of the formatter. An improper voltage jumper setting will cause damage to equipment.

**NOTE**

Later versions of the formatter will have a switch at the rear of the power supply to set the proper input voltage. Set the switch to the **115** position for domestic installations and the **220** position for international installations.

1. Slide the formatter out of its drawer. The jumper is located on the rear of the power supply.
2. Check the AC voltage label above the AC power connector on the rear of formatter for correct voltage setting. Check the voltage jumper to ensure the correct setting. Figure 2-11 shows the location of the formatter's internal power supply jumper:

Figure 2-11, Formatter Voltage Jumper Location and Settings

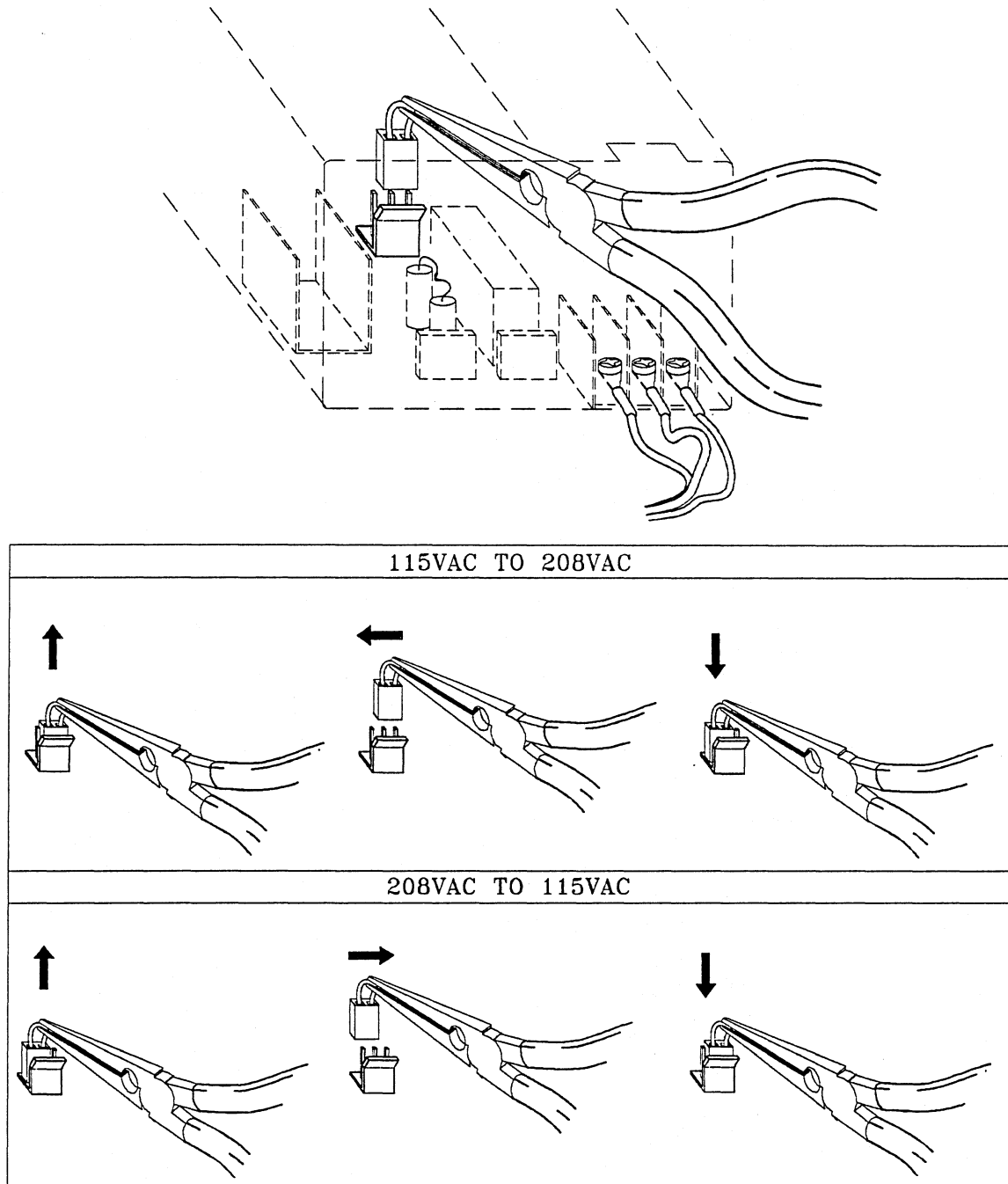

H062017  
4/16/90

3. If the jumper is set incorrectly, use 4-inch needle-nose pliers to remove the jumper and move the jumper to the other configuration. Figure 2-11 shows the correct voltage jumper settings for the formatter's internal power supply.
4. Slide the formatter back into the drawer.

#### **2.3.4.3 Installation of the Formatter**

This section gives the procedure for installing a 3480-compatible formatter.

1. Configure the formatter. To make the formatter compatible with the system, the switches on the differential (DI) card inside the formatter must be set correctly. Figure 2-12 shows the location of the DI card dip switches:

Figure 2-12, DI Card Dip Switches

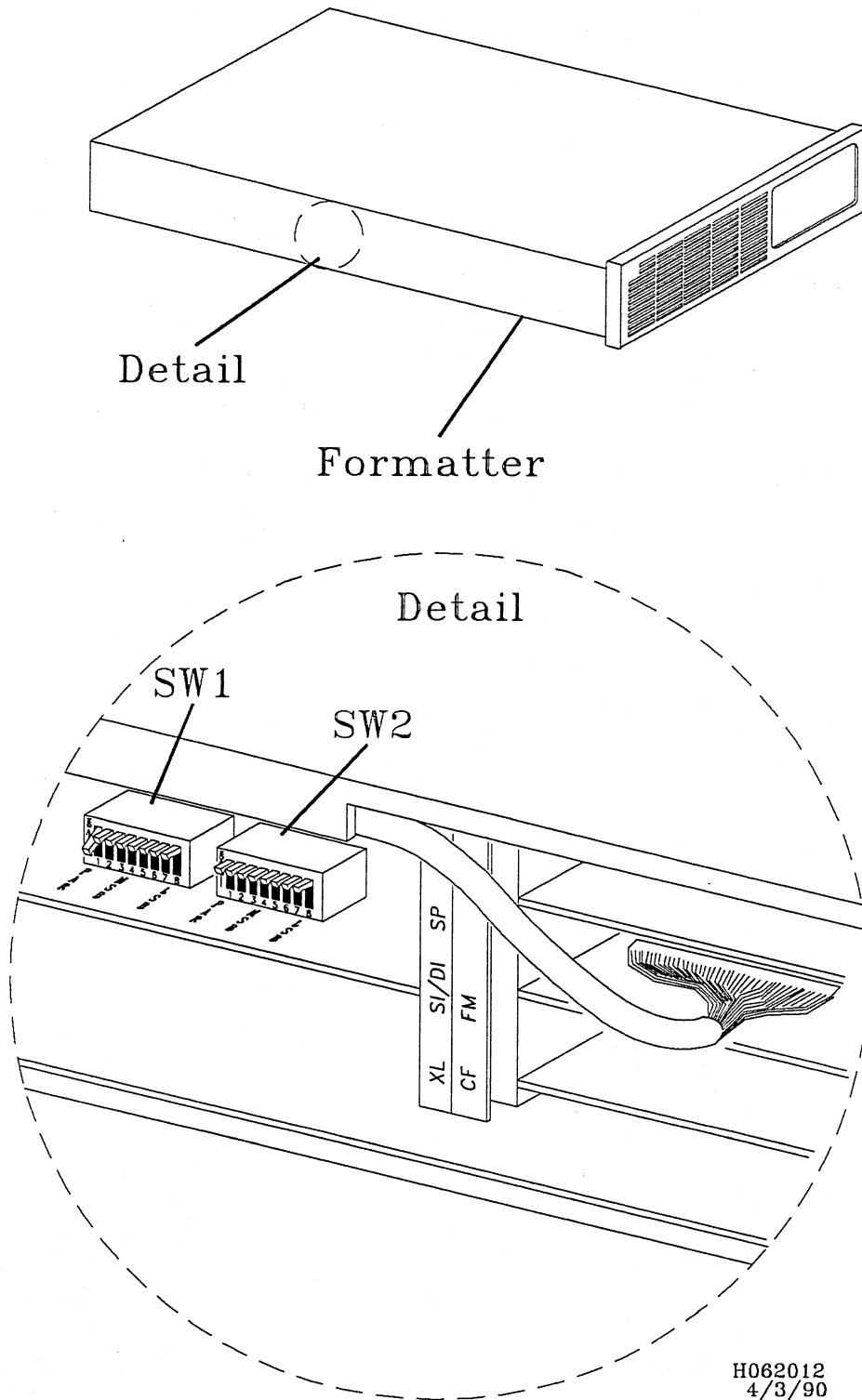

H062012  
4/3/90

Table 2-3 lists the settings for the SW1 dip switch on the DI card:

**Table 2-3, SW1 Jumper Switch Settings on the DI Card**

Address	1	2	3	4	5	6	7	8
000	OFF	ON	ON	ON	ON	ON	ON	ON
001	OFF	ON	ON	ON	ON	ON	ON	OFF
002	OFF	ON	ON	ON	ON	ON	OFF	ON
003	OFF	ON	ON	ON	ON	ON	OFF	OFF

Table 2-4 lists the settings for the SW2 dip switch on the DI card:

**Table 2-4, SW2 Jumper Switch Settings on the DI Card**

1	2	3	4	5	6	7	8
ON	ON	ON	ON	ON	ON	ON	ON

- Remove the rear mounting brackets on the formatter and re-install them on the opposite side of the intermediate RETMA rails. Figure 2-13 shows the rear mounting brackets of the formatter in their shipping and installation configurations:

**Figure 2-13, Formatter Rear Mounting Brackets**

---

Shipping Configuration

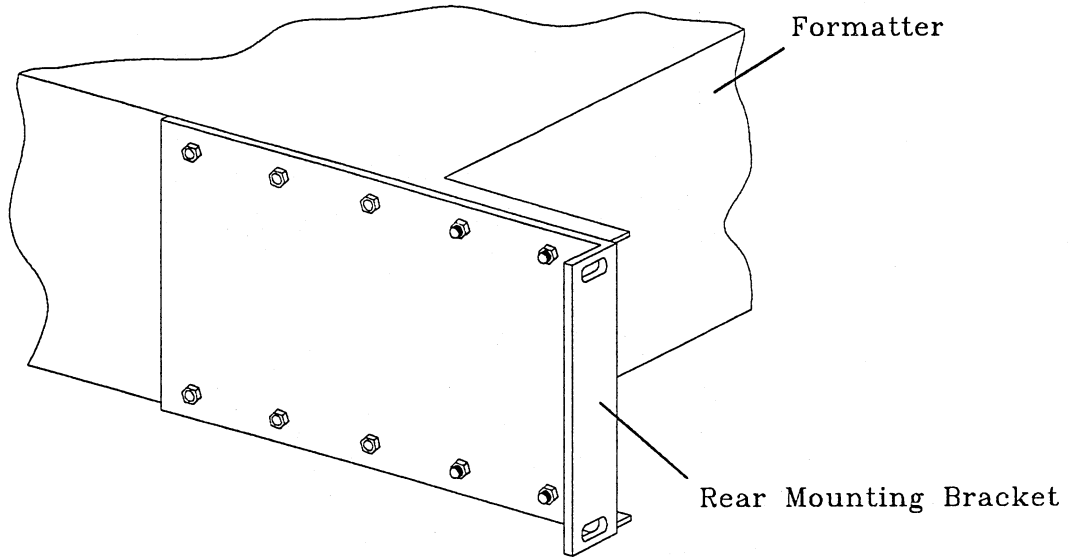

Installation Configuration

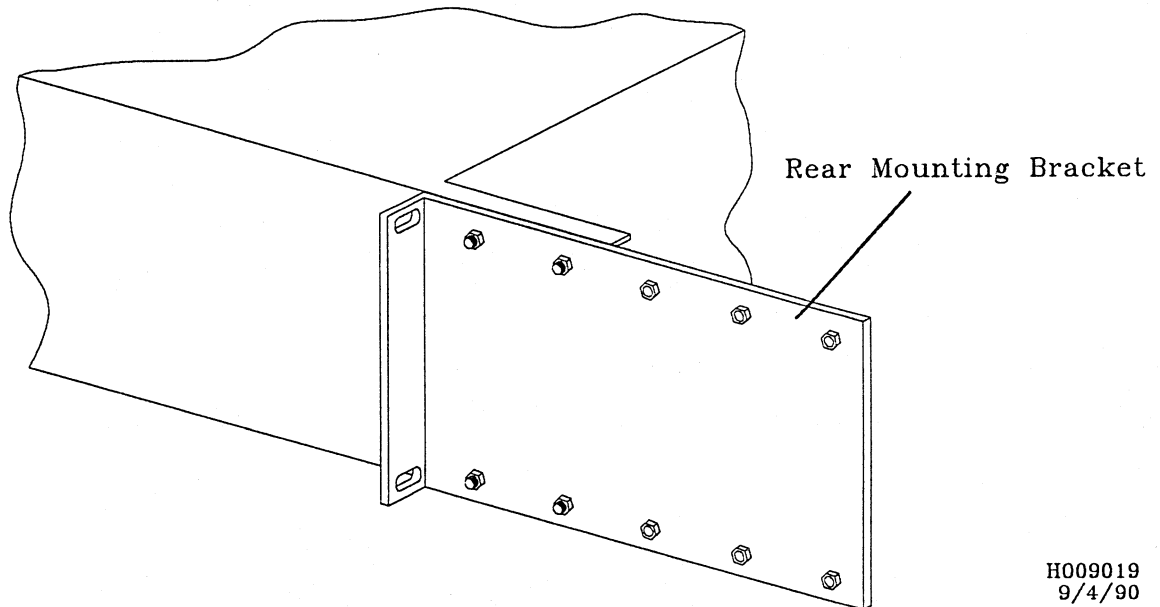

H009019  
9/4/90

3. Install the formatter and mounting frame.

**NOTE**

When installing a formatter in an existing expansion cabinet, the rear mounting brackets of the formatter will need to be removed and re-installed on the opposite side of the intermediate RETMA rails.

4. Cable the **MTU DIGITAL** and the **MTU ANALOG** connectors from the formatter to the keyed connectors on the rear of the tape drive. Figure 2-14 shows the cabling of a 3480-compatible daisy-chain system:

Figure 2-14, Formatter-to-Tape Drive Cabling

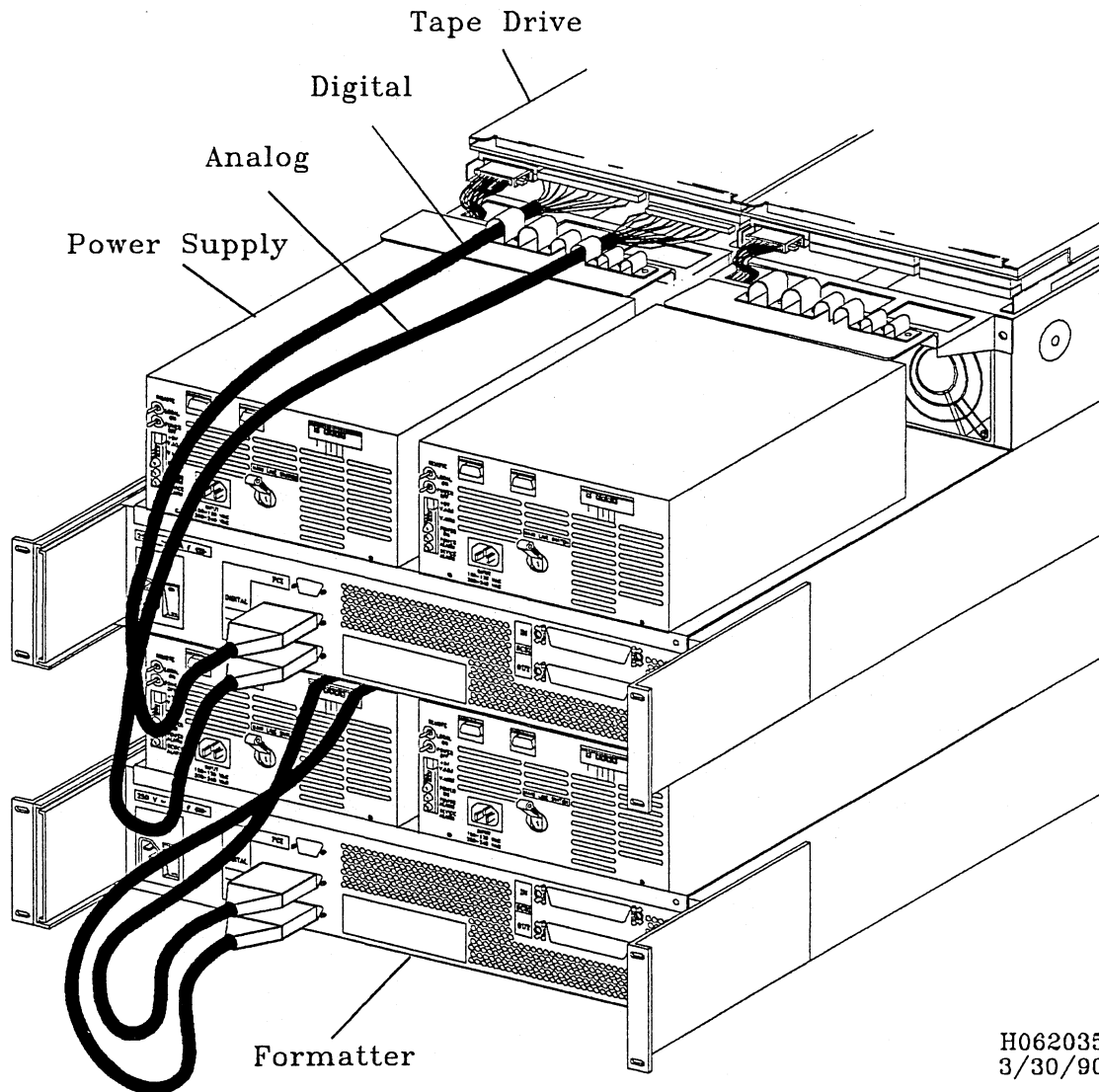

H062035  
3/30/90

**NOTE**

Refer to the *CONVEX VMEbus SCSI Host Adapter Service Guide* for information on installation and cabling of the VMEbus SCSI host adapter.

The maximum cable length allowed between the SCSI host adapter and the formatter is approximately 75 feet (25 meters).

5. Connect the cable from the SCSI host adapter to the **SCSI IN** connector on the rear of the 3480-compatible formatter unit. Install a terminator in the **SCSI OUT** connector.

If the cabinet has an existing formatter, cable the **SCSI IN** connector on the newly-installed formatter to the **SCSI OUT** connector on the last formatter in the daisy chain and install a terminator in the **SCSI OUT** connector of the newly-installed formatter. Figure 2-15 shows the cabling **SCSI IN** and **SCSI OUT** of a formatter daisy-chain:

**CAUTION**

Ensure all terminators are firmly installed. An improperly installed terminator will cause a system failure and possible loss of data.

**NOTE**

A terminator is required in the **SCSI OUT** connector of the only formatter or the last daisy-chained formatter in a system.

Figure 2-15, Formatter-to-Formatter Cabling

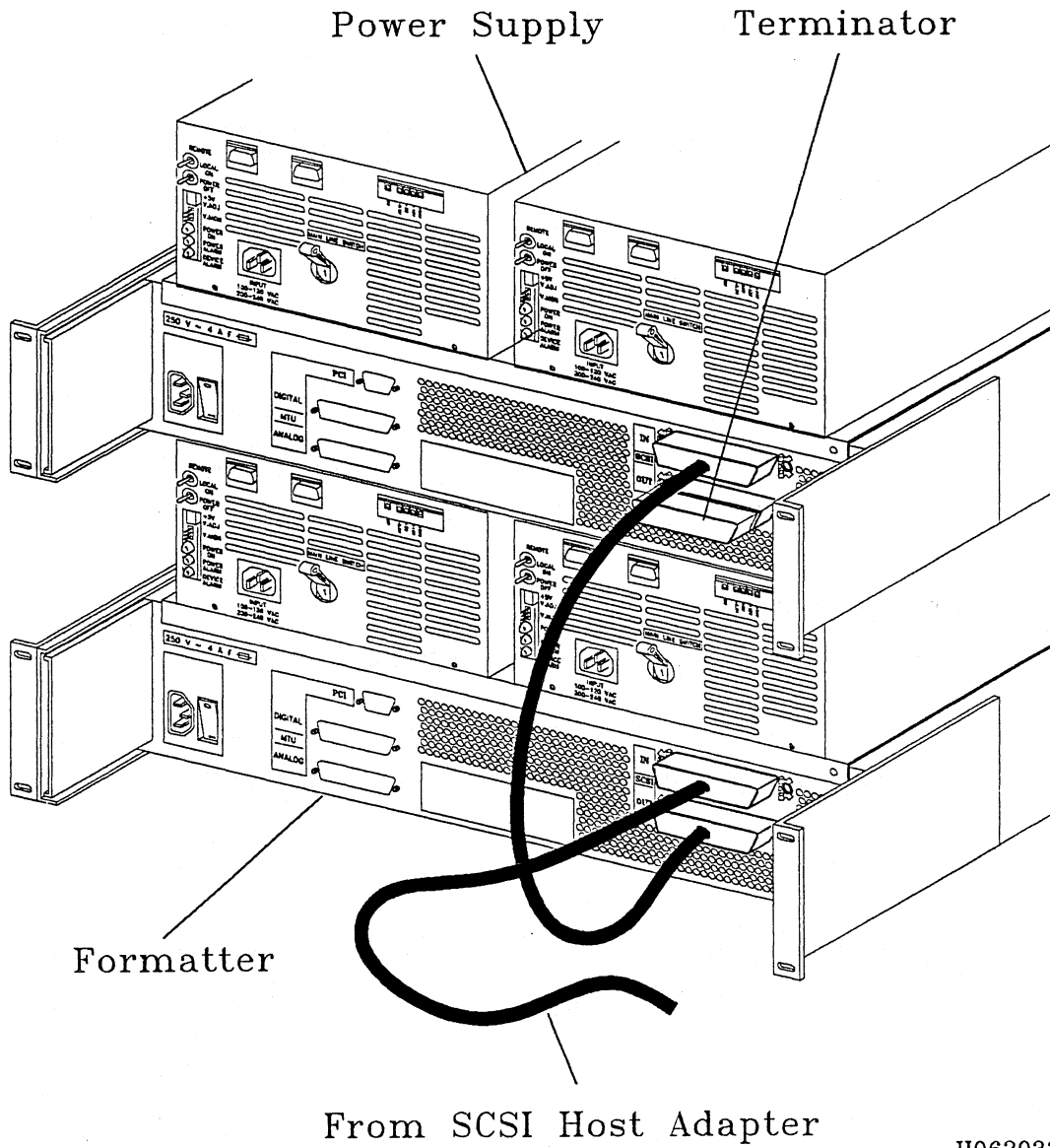

H062032  
6/19/90

6. Install one end of the Power Control Interconnect (PCI) cable into the PCI connector on the back of the formatter. Connect the other end of the cable into the PCI connector of the first cartridge tape drive power supply in the daisy chain.

7. Install one end of another PCI cable into the **PCO** connector of the power supply and the other end into the **PCI** connector of the next power supply in the daisy chain. Connect the remainder of the power supplies in the daisy chain the same way. The **PCO** connector on the last power supply is *not* terminated. Figure 2-16 shows the **PCI-to-PCO** cable connections:

Figure 2-16, PCI-to-PCO Cabling

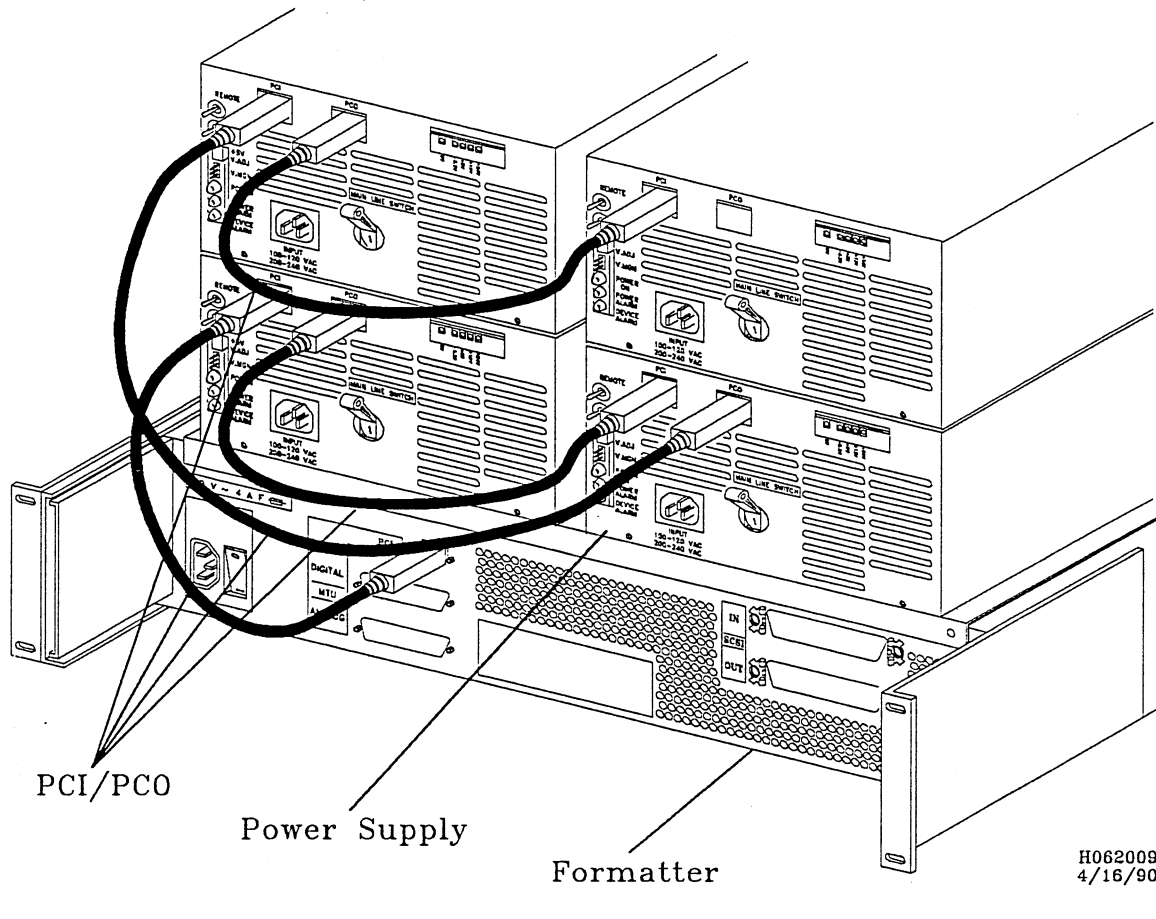

8. Return the expansion cabinet expansion bars to their retracted position.
9. Restore AC power to the expansion cabinet.
  - To restore AC power to a CONVEX EXP-101, EXP-102, or EXP-302 expansion cabinet, connect the cabinet's AC power cord to the AC power source.
  - To restore AC power to a CONVEX EXP-105 or equivalent high-performance expansion cabinet, set the cabinet's main power switch to the **ON** position.
10. Set the processor's front panel key switch to the **ON** position.

## 2.4 Installation of Expansion Cabinet Containing a Cartridge Tape System

This section discusses the installation of an expansion cabinet containing a 3480-compatible cartridge tape system pre-installed at the factory.

### NOTE

Refer to the *CONVEX Installation Guide (C200 Series)*, Chapter 4, "New System Cabinet Installation," section 4.5, "Mating and Securing the Expansion Cabinets," for more information on unpacking and installation of a peripheral expansion cabinet.

1. Remove packaging from around the cabinet.
2. Remove the cabinet from the pallet.
3. Set the processor cabinet's main circuit breaker to the **OFF** position and set the LOCAL/REMOTE switch to the **OFF** position.
4. Mate and secure the expansion cabinet to the processor cabinet.
5. Install the SCSI host adapter in the VMEbus chassis.

### NOTE

Refer to the *CONVEX SCSI Host Adapter Service Guide* for more information on installation of the SCSI host adapter.

The maximum cable length allowed between the SCSI host adapter and the formatter is approximately 75 feet (25 meters).

6. Connect the cable from the SCSI host adapter in the VMEbus chassis to the formatter or the first formatter in the daisy chain.

### NOTE

Refer to section 2.3.4.3, "Installation of the Formatter," for formatter cabling instructions.

# Chapter 3

## Integration and Test

### 3.1 Overview

The CONVEX 3480-compatible cartridge tape system must be integrated into the CONVEX Operating System (ConvexOS) before it can be used. This chapter contains guidelines for integrating a 3480-compatible cartridge tape drive into ConvexOS as well as information on the CONVEX diagnostic tests and internal tests for the 3480-compatible tape drive and the formatter.

#### NOTE

ConvexOS V8.1 or greater is required to operate a CONVEX 3480-compatible cartridge tape system.

ConvexOS V8.1 requires a system generation of the software drivers when a SCSI host adapter and 3480-compatible cartridge tape system are installed.

ConvexOS V9.0 or later contains all the software drivers needed for the SCSI host adapter. This means a system generation is not required when a SCSI host adapter and 3480-compatible cartridge tape system are installed.

### 3.2 Software Integration

The software for the CONVEX 3480-compatible cartridge tape system is released separately from ConvexOS and utilities. Refer to the *ConvexOS System Manager's Guide* for additional software integration information. That document includes a complete description of the software integration procedures for CONVEX 3480-compatible cartridge tape system software.

System-level hardware is identified to ConvexOS via a configuration file (*/ioconfig*) located on the Service Processor Unit (SPU) disk. The */ioconfig* file describes, in hierarchical fashion, the connections between VIOPs, VMEbus chassis number, controller type, Control and Status Register (csr) address, interrupt number, and peripheral device type. The device codes for the 3480-compatible cartridge tape system are listed below:

- MTC-202—SCSI host adapter
- MTD-207—3480 cartridge tape system

Figure 3-1 shows a typical */ioconfig* file with 3480-compatible cartridge tape system and SCSI host adapter specific items in **bold** type:

---

**Figure 3–1, Example */ioconfig* File**

---

```

iop 3
  mbus 0
    ctrl DKC-001 csr 0x3f0 int 2
      unit 0 type DKD-005
    ctrl MTD-001 csr 0x0c0 int 4
      unit 0 type MTC-001
    ctrl ACM-001 csr 0x3c0 int 7
      unit 0 type TTY
      unit 1 type TTY
      unit 2 type TTY
      unit 3 type TTY
      unit 4 type TTY

viop 4
  vme 0
    ctrl LAN-202 csr 0x7740 int 3
      unit 0 type unet

  vme 1
    ctrl MTC-202 csr 0xee00 int 2
      unit 0 subunit 0 type MTD-207
      unit 0 subunit 1 type MTD-207
      unit 0 subunit 2 type MTD-207
      unit 0 subunit 3 type MTD-207
      unit 1 subunit 0 type MTD-207
      unit 1 subunit 1 type MTD-207
      unit 2 subunit 0 type MTD-207
      unit 3 subunit 0 type MTD-207
    ctrl DKC-203 csr 0x800 int 3
      unit 0 DKD-214
      unit 1 DKD-214
    ctrl DKC-203 csr 0xa00 int 4
      unit 0 DKD-214
      unit 1 DKD-214

```

---

Whenever 3480-compatible cartridge tape drives or formatters are added or removed, the information in the hardware section of the configuration file (*/ioconfig*) must be changed, otherwise system operation problems will occur. Refer to the *ConvexOS System Manager's Guide* when making these changes.

### 3.3 Testing the 3480-Compatible Cartridge Tape System

The CONVEX 3480-compatible cartridge tape system is tested by the *dev\_v3480* diagnostic program. This program verifies the operation of the 3480-compatible cartridge tape drive and the 3480-compatible formatter. The *dev\_v3480* diagnostic program verifies the:

- Functional ability of the SCSI host adapter to operate in the CONVEX VMEbus I/O environment. This testing includes main memory access and interrupt generation and detection.
- Ability of the host adapter to detect anomalous conditions on the SCSI bus.
- Operational integrity of the cable interface between the tape controller and the tape unit.

The *dev\_v3480* diagnostic program is an offline program that must be executed on the SPU while the CPU is halted. The procedures for executing this test are beyond the scope of this manual. This information is contained in the *CONVEX PBUS I/O System Diagnostics Manual*; consult that manual before running CONVEX diagnostics.

### 3.4 3480-Compatible Cartridge Tape Internal Tests

The CONVEX 3480-compatible cartridge tape drive has built-in diagnostics for troubleshooting and repair. These tests are accessed via the front panel (OP panel).

**NOTE**

The tape drive must complete power-up procedures before attempting to run any of the built-in diagnostics. Failure to do so will cause the diagnostics to fail.

Refer to *Fujitsu Cartridge Tape Drives CE Manual*, chapter 9, "MAINTENANCE," section 9.4, "Confirmation Test Procedure," for diagnostic test procedures.

Refer to *Fujitsu Cartridge Tape Drives CE Manual*, chapter 9, "MAINTENANCE," section 9.2, "Troubleshooting," for diagnostic and repair information.

### 3.5 3480-Compatible Formatter Internal Tests

The CONVEX 3480-compatible formatter has built-in diagnostics for troubleshooting and repair. These tests are accessed via the front panel (OP panel).

Refer to *Fujitsu Cartridge Tape Controller CE Manual*, chapter 5, "Troubleshooting Via the Front Panel," for diagnostic test procedures and diagnostic test overview.

Refer to *Fujitsu Cartridge Tape Controller CE Manual*, chapter 8, "Offline Routine Control Procedures," for a description of the built-in offline diagnostic tests.

Refer to *Fujitsu Cartridge Tape Controller CE Manual*, chapter 10, "Inline Diagnostic Routines," for a description of the built-in inline diagnostic tests.

Refer to *Fujitsu Cartridge Tape Controller CE Manual*, chapter 11, "Diagnostic Error Codes," for error code identification and explanation.

# Chapter 4

## Maintenance Procedures and IPB

### 4.1 Overview

This chapter gives information on preventative maintenance, removal/replacement procedures, an Illustrated Parts Breakdown (IPB), and CONVEX part numbers for the CONVEX 3480-compatible cartridge tape system.

### 4.2 Cartridge Tape Drive Preventative Maintenance

This section gives information on the preventative maintenance schedules and procedures for the 3480-compatible cartridge tape drive.

#### 4.2.1 Cleaning the Tape Drive

This section describes the cleaning of the 3480-compatible cartridge tape drive:

**NOTE**

Cleaning cartridges may be purchased at the customer's local business supply or computer supply vendor. For more information on vendors, contact your local CONVEX sales office.

1. When cleaning is required, a message is displayed on the operator panel of the tape drive.
2. Insert the cleaning cartridge into the tape drive.
3. When the cleaning process is finished, the cleaning cartridge is rewound and ejected automatically.

**NOTE**

Refer to *Fujitsu Cartridge Tape Drives CE Manual*, chapter 4, "HOW TO OPERATE," section 4.3, "Cleaning," for more information on the cleaning of the tape drive.

### 4.2.2 Filter Maintenance

The 3480-compatible cartridge tape drive has a vane pump filter and an air filter which require replacement at least once a year. New filters may be ordered from your local CONVEX sales office. The following sections give removal/replacement procedures and part numbers for the vane pump filter and the air filter.

## 4.3 Cartridge Tape Drive Maintenance Procedures

This section gives information on the removal/replacement procedures and Integrated Parts Breakdown (IPB) for Field Replaceable Units (FRUs) for the 3480-compatible cartridge tape drive.

### 4.3.1 Tape Drive Unit Removal and Replacement

This section gives the procedure for removing and replacing the 3480-compatible cartridge tape drive:

#### 4.3.1.1 Removal

**CAUTION**

Remove power to the expansion cabinet before removing or servicing any equipment. Failure to do so will cause damage to electronic equipment components.

1. Remove power to the expansion cabinet.

- To remove power from a CONVEX EXP-101 or EXP-102 expansion cabinet, disconnect the AC power cord from the AC power source.
- To remove power from a CONVEX EXP-105 high-performance expansion cabinet, set the main power control switch to the **OFF** position.

**WARNING**

Expansion cabinet stabilizer bars *must* be extended prior to extending any component installed in the expansion cabinet. Failure to do so will make the expansion cabinet unstable, increase the possibility of it falling forward, can cause injury to personnel, and will cause damage to equipment.

2. Extend the expansion cabinet stabilizer bars and adjust the feet until they are in firm contact with the floor. Figure 4-1 shows the expansion cabinet stabilizer bars and adjustable feet:

**Figure 4-1, Expansion Cabinet Stabilizer Bars**

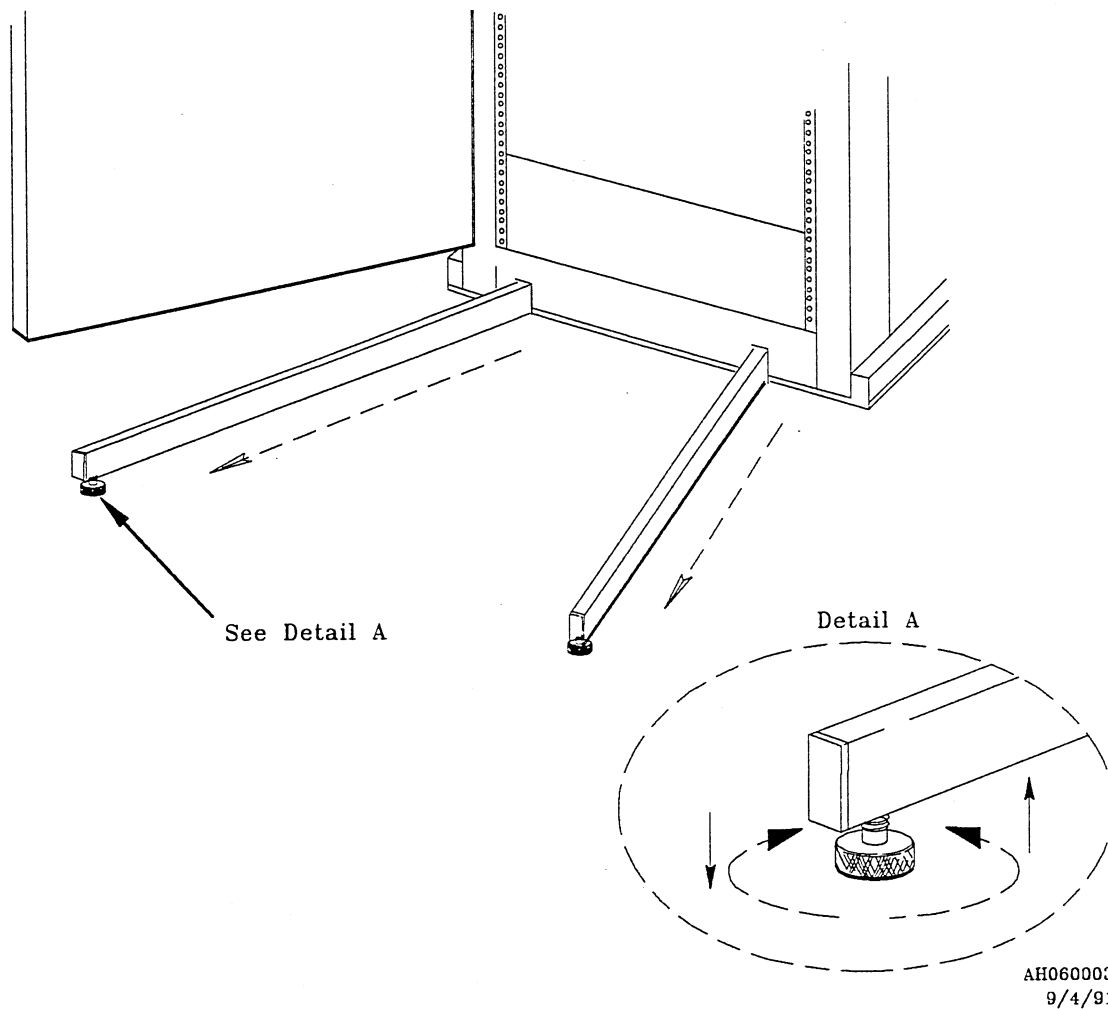

3. Disconnect the target tape drive's power supply's AC power cord from the expansion cabinet's power strip.
4. Remove the 2 screws holding the cartridge tape drive tray and slide the tray partially out of the cabinet.
5. Remove the 2 screws securing the shielding bracket covering the cables and remove the shielding bracket.
6. Mark each cable attached to the tape drive for easy replacement.

7. Remove each cable attached to the tape drive. Remove the terminator from the tape drive (if present).
8. Remove the 2 screws that secure the cable shielding clamp to the tape drive.
9. Remove the 4 screws from the bottom of the tray holding the target tape drive.
10. Remove the tape drive.

#### 4.3.1.2 Replacement

1. Place the replacement tape drive in the tray.
2. Install the 4 screws into the bottom of the tray that holds the replacement tape drive.

**NOTE**

Refer to chapter 2, "Unpacking and Installation," section 2.3.4.1, "Installation of the Cartridge Tape Drive and Power Supply," for more detailed cabling instructions.

3. Install the 2 screws that secure the cable clamp bracket to the tape drive.
4. Install the cables and terminator (if necessary) to the tape drive.
5. Install the shielding bracket over the cable clamp bracket and secure with 2 screws.
6. Slide the tape drive tray back into the expansion cabinet.
7. Install the 2 screws that hold the tray in the expansion cabinet.
8. Connect the power supply's AC power cord to the expansion cabinet's power strip.
9. Return the expansion cabinet stabilizer bars to their retracted position.
10. Return power to the expansion cabinet.
  - To return power to a CONVEX EXP-101 or EXP-102 expansion cabinet, connect the AC power cord to the AC power source.
  - To return power to a CONVEX EXP-105 high-performance expansion cabinet, set the main power control switch to the ON position.

### 4.3.2 Power Supply Removal and Replacement

This section gives the procedure for removing and replacing the power supply of the 3480-compatible cartridge tape drive:

#### 4.3.2.1 Removal

##### CAUTION

Remove power to the expansion cabinet before removing or servicing any equipment. Failure to do so will cause damage to electronic equipment components.

1. Remove power to the expansion cabinet.
  - To remove power from a CONVEX EXP-101 or EXP-102 expansion cabinet disconnect the AC power cord from the AC power source.
  - To remove power from a CONVEX EXP-105 high-performance peripheral cabinet set the main power control switch to the **OFF** position.

##### WARNING

Expansion cabinet stabilizer bars *must* be extended prior to extending any component installed in the expansion cabinet. Failure to do so will make the expansion cabinet unstable, increase the possibility of it falling forward, can cause injury to personnel, and will cause damage to equipment.

2. Extend the expansion cabinet stabilizer bars and adjust the feet until they are in firm contact with the floor. Figure 4-1 shows the expansion cabinet stabilizer bars and adjustable feet.
3. Disconnect the target power supply's AC power cord from the expansion cabinet's power strip.
4. Remove the AC power cord, the **PCI** cable, and the **PCO** cable (if installed) from the rear of the power supply.
5. Remove the 2 screws holding the power supply to the rear of the tray.
6. Remove the 2 screws holding the cartridge tape drive tray and slide the tray partially out of the cabinet.
7. Remove the 2 screws securing the shielding bracket to the tape drive and remove the shielding bracket.
8. Remove the DC power cable from the front of the power supply.
9. Remove the 2 screws from the bottom front of the power supply securing it to the tray.

10. Remove the power supply from the tray.

#### 4.3.2.2 Replacement

1. Install the new power supply.
2. Install the 2 screws to the bottom front of the power supply securing it to the tray.
3. Connect the DC power cable to front of power supply.
4. Install the shielding bracket the 2 screws that secure it.
5. Slide the tray back into the cabinet and install the 2 screws holding the tray to the cabinet.
6. Install the 2 screws to the rear of the power supply that secure it to the tray.
7. Connect the **PCI** cable, the **PCO** cable (if necessary), and the AC power cable to the rear of the power supply.
8. Connect the power supply's AC power cord to the expansion cabinet's power strip.
9. Return the expansion cabinet stabilizer bars to their retracted position.
10. Return power to the expansion cabinet.
  - To return power to a CONVEX EXP-101 or EXP-102 expansion cabinet connect the AC power cord.
  - To return power to a CONVEX EXP-105 high-performance expansion cabinet set the main power control switch to the **ON** position.

#### 4.3.3 Air Filter Removal/Replacement

Refer to the *Fujitsu Cartridge Tape Drives CE Manual*, chapter 9, "MAINTENANCE," section 9.3.8, "Filter replacement," for the procedures to remove and replace the air filter.

#### 4.3.4 Vane Pump Filter Removal/Replacement

Refer to the *Fujitsu Cartridge Tape Drives CE Manual*, chapter 9, "MAINTENANCE," section 9.3.9, "Vane pump filter replacement," for the procedures to remove and replace the vane pump filter.

#### 4.3.5 CR Board Removal/Replacement

Refer to the *Fujitsu Cartridge Tape Drives CE Manual*, chapter 9, "MAINTENANCE," section 9.3.15, "PCA-CR removal/mounting (with bracket)," for the procedures to remove and replace the CR board.

#### 4.3.6 OP Panel Board Removal/Replacement

Refer to the *Fujitsu Cartridge Tape Drives CE Manual*, chapter 9, "MAINTENANCE," section 9.3.2, "PCA-OP replacement," for the procedures to remove and replace the OP panel board.

## 4.4 Formatter Maintenance Procedures

This section gives information on the removal/replacement procedures and IPB for Field Replaceable Units (FRUs) for the 3480-compatible system formatter.

### 4.4.1 Formatter Unit Removal/Replacement

This section gives information on the removal and placement of the 3480-compatible formatter:

#### 4.4.1.1 Removal

##### CAUTION

Remove power to the expansion cabinet before removing or servicing any equipment. Failure to do so will cause damage to electronic equipment components.

1. Remove power to the expansion cabinet.
  - To remove power from a CONVEX EXP-101 or EXP-102 expansion cabinet, disconnect the AC power cord from the power source.
  - To remove power from a CONVEX EXP-105 high-performance expansion cabinet, set the main power control switch to the **OFF** position.

##### WARNING

Expansion cabinet stabilizer bars *must* be extended prior to extending any component installed in the expansion cabinet. Failure to do so will make the expansion cabinet unstable, increase the possibility of it falling forward, can cause injury to personnel, and will cause damage to equipment.

2. Extend the expansion cabinet stabilizer bars and adjust the feet until they are in firm contact with the floor. Figure 4-1 shows the expansion cabinet stabilizer bars and adjustable feet.
3. Mark all cables connected to the rear of the formatter for easy reconnection.
4. Disconnect the AC power cable, the **PCI** cable, the **MTU DIGITAL** cable, the **MTU ANALOG** cable, the **SCSI IN**, and the **SCSI OUT** cable from the rear of the formatter.
5. Slide the formatter out of the cabinet.

#### 4.4.1.2 Replacement

1. Install new formatter into cabinet.
2. Connect the AC power cable, the **PCI** cable, the **MTU DIGITAL** cable, the **MTU ANALOG** cable, the **SCSI IN**, and the **SCSI OUT** cable to the rear of the formatter.
3. Return the expansion cabinet stabilizer bars to their retracted position.
4. Return power to the expansion cabinet.
  - To return power to a CONVEX EXP-101 or EXP-102 expansion cabinet, connect the AC power cord.
  - To return power to a CONVEX EXP-105 high-performance expansion cabinet, set the main power control switch to the **ON** position.

#### 4.4.2 PC Board Removal/Replacement

**NOTE**

A special tool (CONVEX part number 900-000235-001) is required to remove the PC boards from the formatter.

Refer to *Fujitsu Cartridge Tape Controller Customer Engineering Manual*, chapter 3, “FRU REMOVE AND REPLACE PROCEDURES,” sections 3.5.1, “PCBA removal” and 3.5.2, “PCBA replacement,” for the procedures to remove and replace PC boards within the formatter.

#### 4.4.3 OP Panel Assembly Removal/Replacement

Refer to the *Fujitsu Cartridge Tape Controller Customer Engineering Manual* chapter 3, “FRU REMOVAL AND REPLACEMENT,” sections 3.5.3, “Front panel removal” and 3.5.4, “Front panel replacement,” for the procedures to remove and replace the OP panel assembly.

#### 4.4.4 Fan Removal/Replacement

Refer to the *Fujitsu Cartridge Tape Controller Customer Engineering Manual* chapter 3, “FRU REMOVAL AND REPLACEMENT,” sections 3.5.7, “Power supply fan removal,” and 3.5.8 “Power supply fan replacement,” for the procedures to remove and replace the power supply fan.

#### 4.4.5 Power Supply Removal/Replacement

Refer to the *Fujitsu Cartridge Tape Controller Customer Engineering Manual* chapter 3, “FRU REMOVAL AND REPLACEMENT,” sections 3.5.5, “Power supply removal,” and 3.5.6, “Power supply replacement,” for the procedures to remove and replace the power supply.

## 4.5 3480-Compatible Cartridge Tape Drive Part List

Table 4-1 lists the part numbers and descriptions for the FRUs of the 3480-compatible cartridge tape drive:

**Table 4-1, 3480-Compatible Cartridge Tape Drive Parts List**

Part Number	Description
207-000015-201	TAPE DR,CART 3MBS,SCSI/DIFF IF BLK
207-000015-003	POWER SUPPLY, 3480 CART TAPE SYSTEM
900-000502-001	CR BOARD, FUJITSU 3480 TAPE
900-000501-001	OP BOARD, FUJITSU 3480 TAPE
900-000503-001	VANE PUMP FILTER, FUJITSU 3480 TAPE
900-000504-001	AIR FILTER, FUJITSU 3480 TAPE
207-000015-014	TERMINATOR, 3480 TAPE DRIVE

**NOTE**

Refer to *Fujitsu Cartridge Tape Drives CE Manual*, chapter 9, "MAINTENANCE," section 9.3, "Parts Replacement," for part identifications.

## 4.6 3480-Compatible Formatter Parts List

Table 4-2 lists the part numbers and descriptions for the FRUs of the 3480-compatible cartridge tape formatter:

**Table 4-2, 3480-Compatible Formatter Parts List**

Part Number	Description
207-000015-024	CNTRL/FMTR, 3MBS DIFF/SCSI BLACK
900-000500-001	RA BOARD, FUJITSU 3480 FORMATTER
900-000509-001	FM BOARD, FUJITSU 3480 FORMATTER
900-000510-001	DI BD, FUJITSU 3480 FORMATTER
900-000508-001	XL BOARD, FUJITSU 3480 FORMATTER
900-000506-001	OP PANEL, FUJITSU 3480 FORMATTER
900-000507-001	FAN, FUJITSU 3480 FORMATTER
900-000505-001	PWR SUPPLY, FUJITSU 3480 FORMATTER

**NOTE**

Refer to *Fujitsu Cartridge Tape Controller Customer Engineering Manual*, chapter 4, "ILLUSTRATED PARTS CATALOG," for part identifications.

## 4.7 3480-Compatible Cartridge Tape System Cable List and IPB

Table 4-3 lists the part numbers, descriptions, and figure item numbers of the cables for a 3480-compatible cartridge tape system:

**Table 4-3, 3480-Compatible Cartridge Tape System Cable List**

Part Number	Description	Item Number
605-030004-202	CABLE ASSY, JUMPER, 3COND, 18 AWG 20" <sup>1</sup>	1,4
304-000017-001	CORD SET, PWR, 115V (AMERICAN) <sup>2</sup>	1,4
304-000017-002	CORD SET, PWR, 220V (AMERICAN) <sup>2</sup>	1,4
207-000015-017	CABLE ASSY, POWER CONTROL (PC) 3480	2
604-500006-200	CABLE ASSY, STD/CINCH SHLD 20 FT	3
604-500006-201	CABLE ASSY, STD/CINCH SHLD 50 FT	3
604-500006-202	CABLE ASSY, STD/CINCH SHLD 10 FT	3
207-000015-011	TERMINATOR, SCSI, DIFF	5
207-000015-012	CABLE SET, CTC-CTU, 2 METERS	6
900-000025-003	CABLE ASSY, DIGITAL CTC-CTU 3480	6
900-000025-004	CABLE ASSY, ANALOG CTC-CTU 3480	6
604-500013-200	CABLE ASSY, CINCH/CINCH PLUG 2.0FT	7
604-500013-201	CABLE ASSY, CINCH/CINCH PLUG 5 FT	7
604-500013-202	CABLE ASSY, CINCH/CINCH PLUG 10 FT	7
207-000015-020	CABLE, DC POWER 3480 TAPE DR	8
207-000015-006	CABLE SET, CTU-CTU, 2 METERS	9,10
900-000025-001	CABLE ASSY, ANALOG CTU-CTU 3480	9
900-000025-002	CABLE ASSY, DIGITAL CTU-CTU, 3480	10

<sup>1</sup> This is used with the EXP-105 High Performance Peripheral Cabinet (HPPC).

<sup>2</sup> This is used with a standard EXP-101 or EXP-102 peripheral cabinet.

Figures 4-2 and 4-3 show the IPB callouts for the cables of a 3480-compatible cartridge tape system:

Figure 4-2, 3480-Compatible Cartridge Tape System Cable IPB # 1

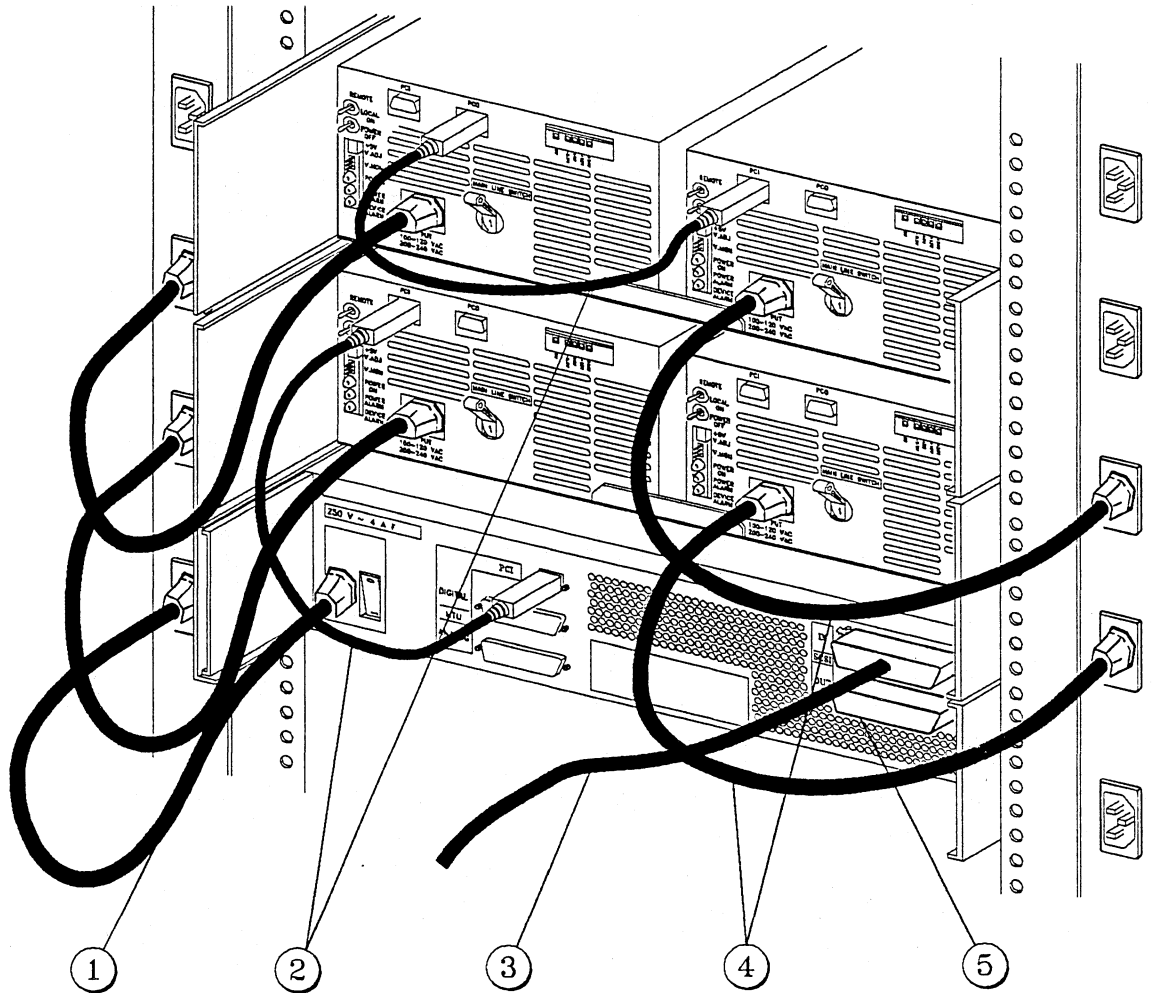

H062041  
4/18/90

Figure 4-3, 3480-Compatible Cartridge Tape System Cable IPB #2

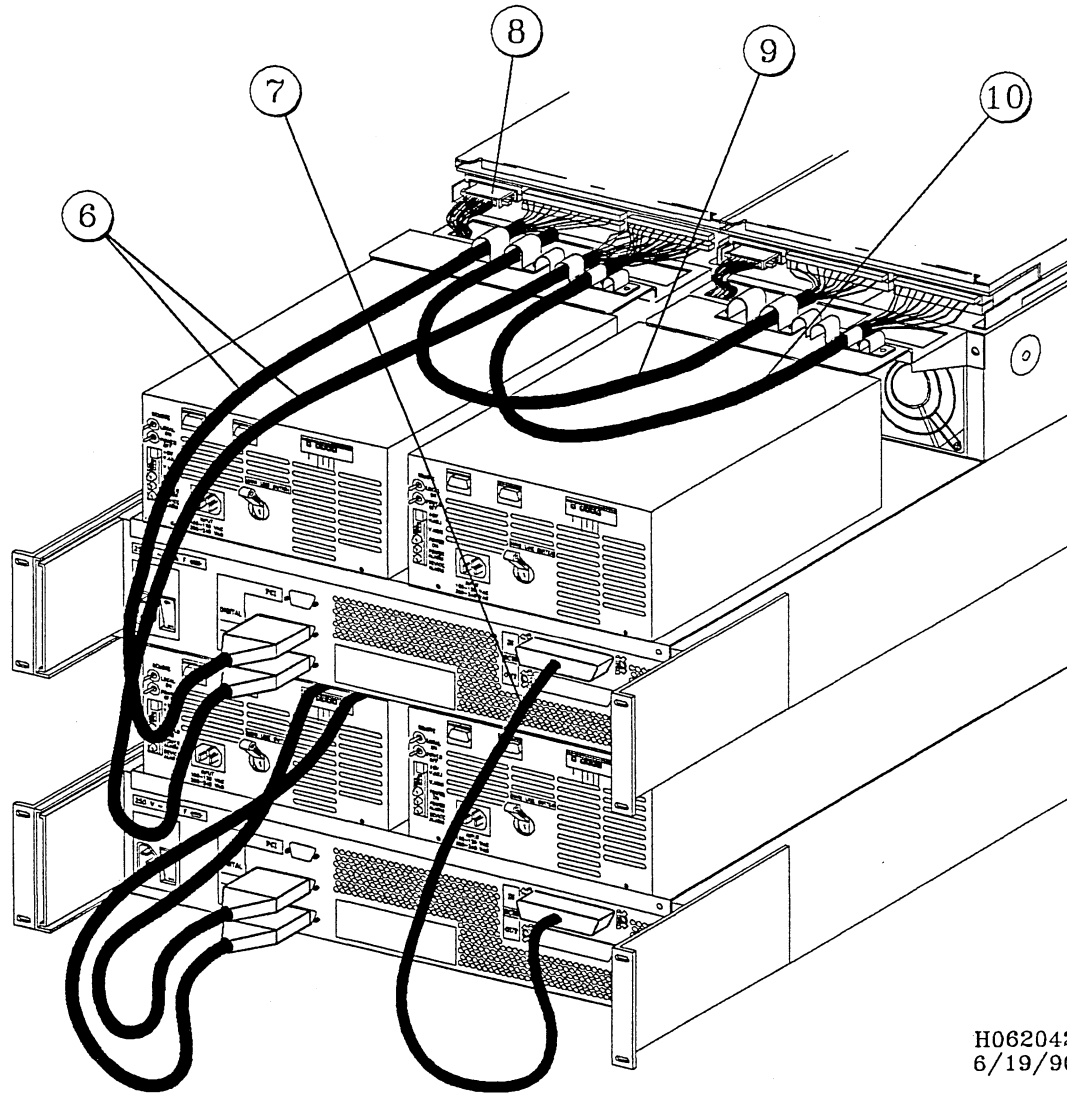

H062042  
6/19/90

**THIS PAGE INTENTIONALLY LEFT BLANK**

# Appendix A

## Fujitsu 2481B Tape Subsystem Configurator

This appendix contains a copy of the Fujitsu 2481B Tape Subsystem Configurator document.

### NOTE

The *Fujitsu 2481B Tape Subsystem Configurator* document contains basic configuration information for the 3480-compatible tape subsystem. In the event of changes regarding Fujitsu 2481B tape subsystem configuration, an updated version of the document will be made available. Configurator document updates should be inserted into this appendix.

# Fujitsu 2481B 3480 Compatible Tape Subsystem

## 1.1 Scope

The purpose of this document is to provide configuration information for the Fujitsu 2481B Tape Subsystem.

The Tape subsystem consist of two units minimum. At least one tape drive, either PN 207-000015-200 or PN 207-000015-201, and one formatter PN 207-000015-008 or PN 207-000015-024. To configure the subsystem extend the formatter and set the switches on the DI board. It is the inner most board in the slot marked SI/DI. There are no switches to be set on the Tape Unit.

## 1.2 Tape Subsystem Configuration

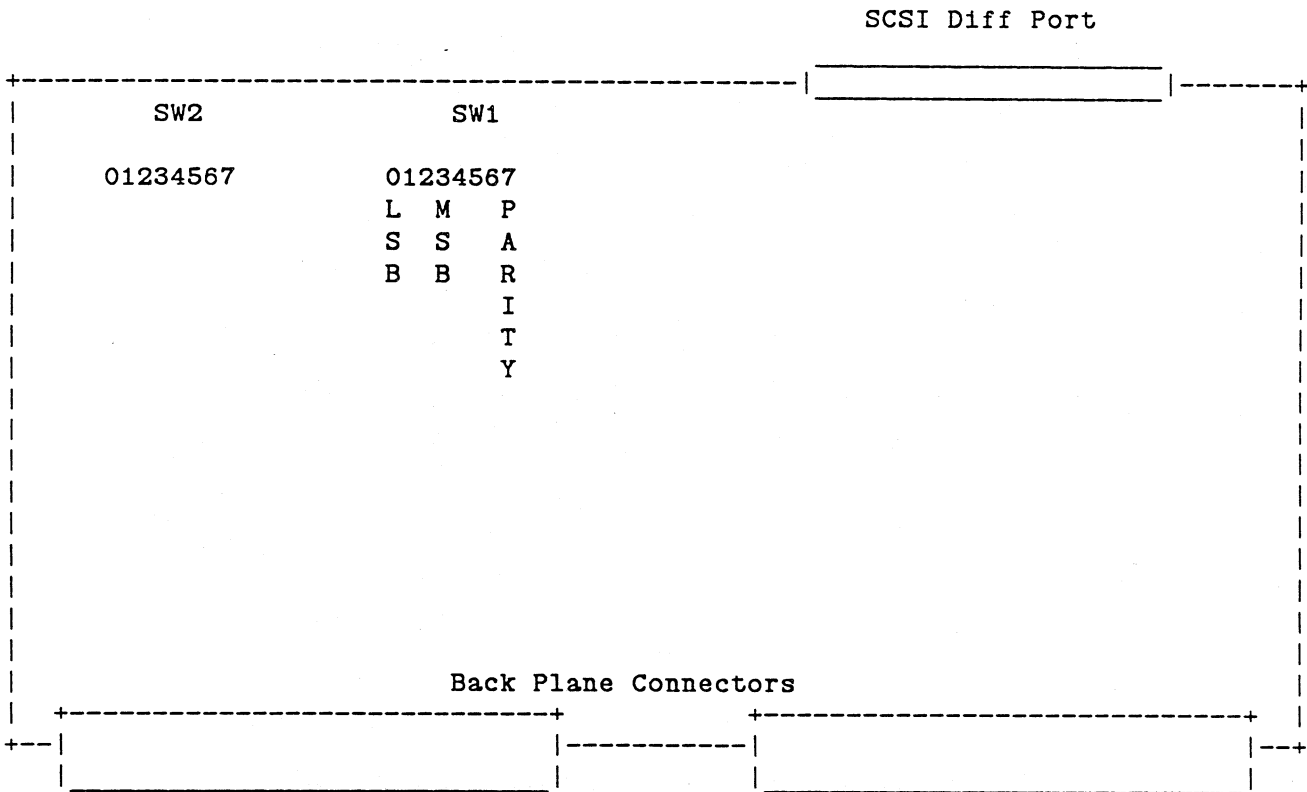

Normal Usage: Base Address of 1st controller in the SCSI BUS is normally "0".

The Interrupt Level determined by SW2 is always deactivated.

COMPANY CONFIDENTIAL. COPYRIGHT CONVEX COMPUTER CORPORATION 1991



CONVEX

TITLE: Fujitsu 2481B Tape Subsystem  
Configurator  
METHOD #: 207-000015-600

REV: B.0 08/28/90

ENGR: John Rachels

PAGE: 1

# Fujitsu 2481B 3480 Compatible Tape Subsystem

## 1.2 Tape Subsystem Configuration

### Jumper & Switch Setting Options:

NOTE: The switch banks SW1 and SW2 indicate "ON" in the deactivated or UP position. Activated or "OFF" is in the DOWN position. Convex uses Parity, so, switch "7", the Parity switch, the eighth switch of SW1, must always be activated, i.e., set to "OFF", the down position.

### SCSI DEVICE ADDRESS SWITCH SETTINGS

BASE ADDRESS	0	1	2	3	7
0	ON	ON	ON	ON	OFF
1	OFF	ON	ON	ON	OFF
2	ON	OFF	ON	ON	OFF
3	OFF	OFF	ON	ON	OFF

### NOTE:

Switches 4-6 on SW1 are used for trouble shooting. They set an RS232 address to allow a terminal connection. Refer to CE manual 900-000444-001.

The AC power for the Formatter can be set to 110VAC or 230VAC. To set the power supply it is necessary to open the Formatter and move a jumper in the power supply. To execute this maneuver properly refer to the procedure defined in the CTU Service Guide, Convex PN 081-003330-000.

The Tape Drive Unit has a user interface for setting address of the unit and other data. Refer to the CE manual 900-000443-001 or the Convex Service Guide, Convex PN 081-003330-000.

In configuring the system for high performance, it is recommended that no more than two tape drives be attached to a formatter with no more than two formatters per host adapter.

For lower performance up to four formatters with four tape drives per formatter may be installed on one host adapter.

### DOCUMENT REVISION HISTORY

REVISION	ECN NO.	DESCRIPTION	DATE	APPROVED
A	106507	Initial Rel	06/20/90	
B	106698	Switch Change	08/27/90	

COMPANY CONFIDENTIAL. COPYRIGHT CONVEX COMPUTER CORPORATION 1991



CONVEX

TITLE: Fujitsu 2481B Tape Subsystem  
Configurator  
METHOD #: 207-000015-600

REV: B.0 08/28/90  
ENGR: John Rachels  
PAGE: 2

**THIS PAGE INTENTIONALLY LEFT BLANK**

# Appendix B

## Automatic Cartridge Loader (ACL)

### B.1 Overview

The CONVEX 3480-compatible cartridge tape subsystem has an optional Automatic Cartridge Loader (ACL) that mounts to the front of the tape drive and accommodates a 10-cartridge magazine.

This appendix contains the *Fujitsu Cartridge Tape Drives CE Manual*, Chapter 10, "Automatic Cartridge Loader (ACL)," sections 10.1 and 10.2, which describe the operation and installation of the ACL mechanism.

**NOTE**

Although the Fujitsu documentation discusses a 5-cartridge magazine, CONVEX only sells a 10-cartridge magazine.

**THIS PAGE INTENTIONALLY LEFT BLANK**

# CHAPTER 10 AUTOMATIC CARTRIDGE LOADER (ACL)

<b>10.1</b>	<b>Specifications</b>
<b>10.2</b>	<b>Operation</b>
<b>10.3</b>	<b>Installation Procedure</b>

This option realizes that the cartridge set in the magazine (for five or ten cartridges) is loaded or ejected into/from the drive automatically.

This option consists of the magazine that stores cartridges, elevator section that ascends or descends the magazine, magazine guide section, feeder section that loads or unloads the cartridge into/from the tape drive, mechanism control section, and operator panel.

## 10.1 Specifications

### 10.1.1 Automatic cartridge loader performance

	Item	Performance		
1	Outer dimensions (W × H × D)	217 × 127 × 226 mm [8.5 × 5.0 × 8.9 in.]		
2	Weight	8 kg (17.6 lbs) or less		
3		10-cartridge magazine	5-cartridge magazine	
	Processing time	Initial loading time	37 sec. max.	
		Cartridge position change time	41 sec. max.	
		Loading time	26 sec. max.	
		Unloading time	12 sec. max.	
		Ejecting time	32 sec. max.	25 sec. max.

**Note:**

Each of processing time is a time from following A to B.

	A	B
Initial loading time	The START switch is pressed.	The cartridge is loaded and the head is positioned on the BOT (ready state).
Cartridge position change time	Ready state	The cartridge is ejected, next cartridge is loaded, and the head is positioned on the BOT.
Loading time	The cartridge is started to load from the magazine	Ready state
Unloading time	Ready state	The cartridge is unloaded into the magazine.
Ejecting time	Ready state	The cartridge is unloaded and the magazine can be removed.

### 10.1.2 Magazine specification

	Item	10-cartridge type	5-cartridge type
1	Outer dimensions (W × H × D)	128 × 388 × 139 mm [5.0 × 15.3 × 5.5 in.]	128 × 231 × 139 mm [5.0 × 9.1 × 5.5 in.]
2	Weight	Without cartridge	1.5 kg (3.3 lbs)
		With cartridge	4.0 kg (8.8 lbs)
			1.0 kg (2.2 lbs)
			2.3 kg (5.1 lbs)

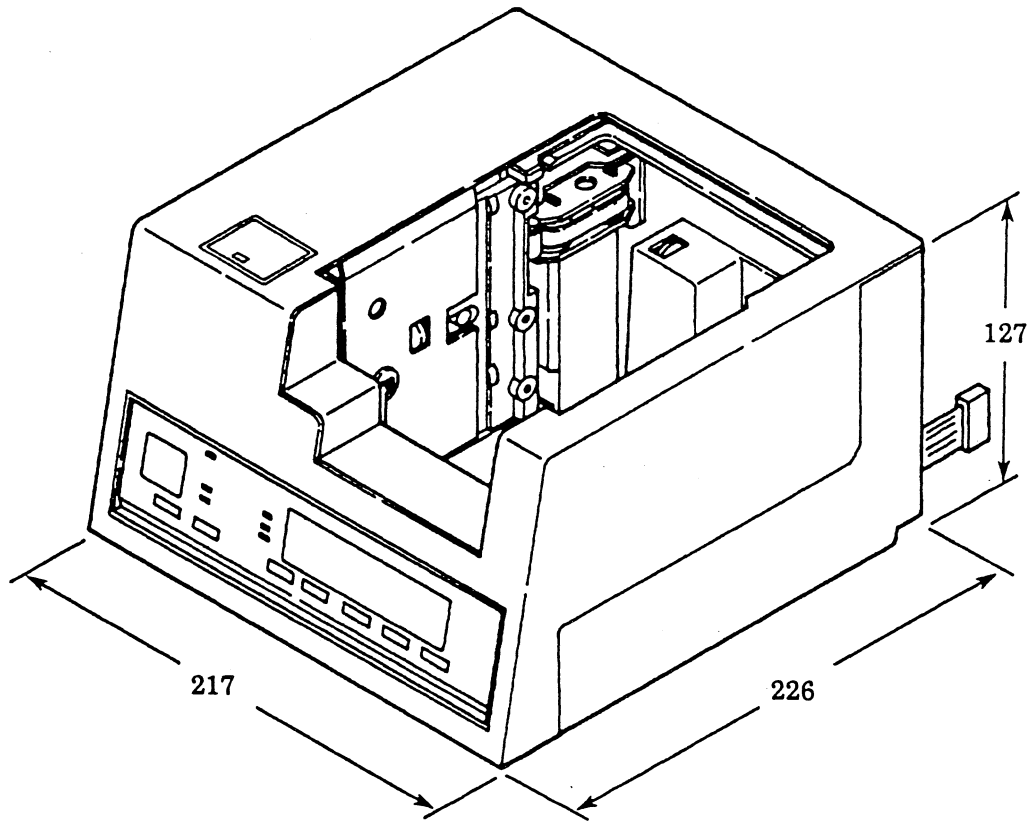

**Figure 10.1 Automatic cartridge loader outer view**

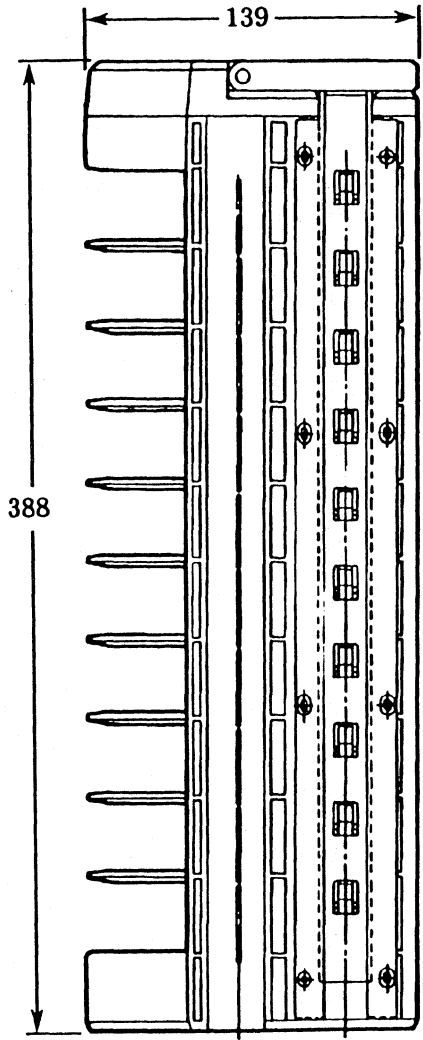

(5-cartridge type : 231)

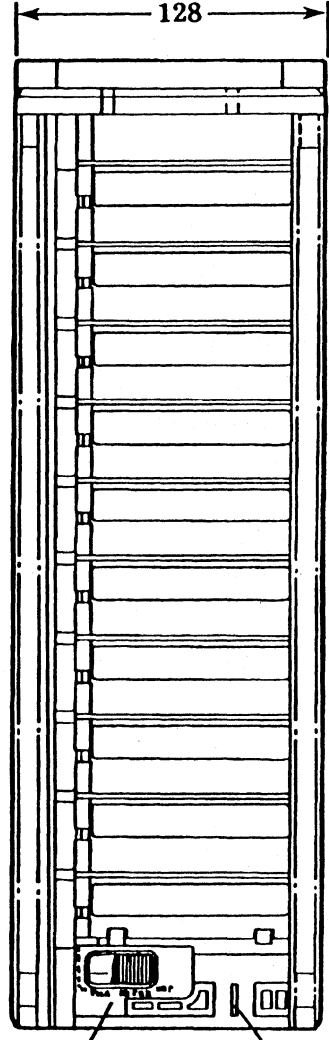

File protect Top sensor flag

Figure 10.2 10-cartridge magazine outer view

## 10.2 Operation

### 10.2.1 Automatic cartridge loader operator panel

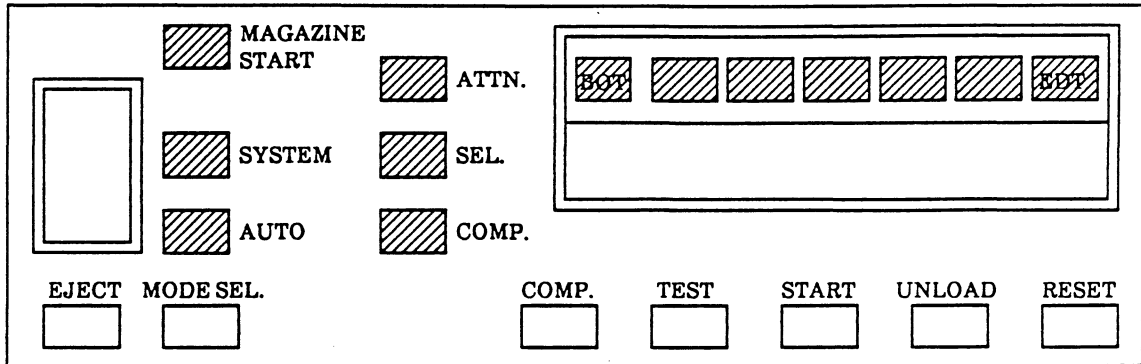

Figure 10.3 Automatic cartridge loader operator panel

Functions equipped on the operator panel of the automatic cartridge loader (ACL) is the same as the tape drive without the ACL except some functions (refer to Section 4.4).

#### (1) Switch

There are seven switches on the operator panel. Following explains the function of each switch. When the switch is pressed except the case that the maintenance function is activated, a message indicating the operation of that switch is displayed. This means that the operator can confirm the switch operation.

##### a. COMP switch

This switch function is the same as the switch of the drive without ACL (refer to Subsection 4.4.2).

##### b. TEST switch

This switch function is the same as the switch of the drive without ACL (refer to Subsection 4.4.2).

##### c. START switch

When the cartridge is set in the magazine and the cartridge is not loaded yet during the AUTO MODE LED lights, the cartridge is loaded by pressing this switch.

Under the condition that the cartridge is already loaded and the tape drive is in not ready state, when the head is positioned at the BOT, the tape drive enters the ready state by pressing this switch, and when the head is positioned at other

than the BOT, the tape drive enters the ready state after rewinding the tape by pressing this switch.

When the ACL is in the stop state (MAGAZINE START LED is off), the ACL enters the start state by pressing this switch.

d. UNLOAD switch

The cartridge is unloaded and ejected into the magazine manually by pressing this switch. When this switch is pressed under the condition that the tape drive is in the not ready state or an error occurs, the cartridge is unloaded and ejected or the error state is reset.

The magazine position can be changed by pressing this switch and the EJECT or MODE SEL switch.

When the magazine is not set;

- The position indication increases by pressing the EJECT switch while pressing the UNLOAD switch.
- The position indication decreases by pressing the MODE SEL switch while pressing the UNLOAD switch.
- When the magazine is set after selecting the position by the above, the magazine is positioned to first cartridge and then to the selected cartridge by pressing the START switch.
- When the 5-cartridge magazine is set and the selected position exceeds 5, the magazine is not loaded even if the START switch is pressed.
- When the RESET switch is pressed before the START switch is pressed, the position selection is canceled and the normal operation is performed.

When the magazine is set, the cartridge is not loaded, and the MAGAZINE START LED is off;

- The magazine position goes up one step by pressing the EJECT switch while pressing the UNLOAD switch.
- The magazine position goes down one step by pressing the MODE SEL switch while pressing the UNLOAD switch.

e. RESET switch

By pressing this switch, the tape drive enters the not ready state and the ACL enters the stop state. At this time, the MAGAZINE START LED goes off and the TEST, START, UNLOAD, and EJECT switch becomes enable. In the case that an error occurs, the error state is reset and the cartridge is unloaded or the magazine is ejected by pressing this switch.

f. **EJECT switch**

By pressing this switch, the cartridge is ejected into the magazine and the magazine is ejected. In the case that an error occurs, the error state is reset and the magazine is ejected by pressing this switch. This switch is effective only when the MAGAZINE START LED is off.

The magazine position can be changed by pressing the UNLOAD switch and this switch. For details, see the explanation of the UNLOAD switch.

g. **MODE SEL switch**

This switch is used to change the ACL mode; system or auto mode. This switch is effective when the MAGAZINE START LED is off.

The magazine position can be changed by pressing the UNLOAD switch and this switch. For details, see the explanation of the UNLOAD switch.

h. **Maintenance function**

This function is the same as the drive without ACL (refer to Subsection 4.4.2).

(2) **Indicator**

a. **ATTN LED**

This LED has the same function as one on the drive without ACL (refer to Subsectin 4.4.3).

b. **SEL LED**

This LED has the same function as one on the drive without ACL (refer to Subsection 4.4.3).

c. **COMP LED**

This LED has the same function as one on the drive without ACL (refer to Subsection 4.4.3).

d. **Remaining tape length LEDs**

These LEDs have the same function as ones on the drive without ACL (refer to Subsection 4.4.3).

e. **Message display**

This display has the same function as one on the drive without ACL (refer to Subsection 4.4.3).

f. **MAGAZINE START LED**

This LED goes on when the magazine is set and the ACL enters the start state by pressing the START switch.

This LED goes off when the ACL enters the stop state, when an error regarding the magazine occurs, or when the magazine is ejected by the EJECT command.

g. **SYSTEM LED**

This LED goes on when the ACL is in the system mode.

h. **AUTO LED**

This LED goes on when the ACL is in the auto mode.

i. **Position indicator**

This indicator indicates the state of the ACL.

(3) **Meaning of messages or indication**

a. **Messages on message display**

These are the same as ones of the drive without ACL (refer to Subsection 4.4.4).

b. Position indicator

Indication	Meaning
"off"	No magazine is set.
1,2,3,4,5, 6,7,8,9,0	Magazine position "0" indicates 10th cartridge.
-	The magazine is set and the START switch is not pressed yet.
F	The magazine is ejected and the magazine is changeable. When the magazine is removed, this LED goes off.
E	An error occurs at the ACL.
H	The cartridge is being inserted or loaded manually without using the magazine.
A	The ACL takes same operations when the power is re-turned on with the magazine is set, when the magazine is loaded or ejected, or when the stopper operation of the magazine is performed.

(4) Mode

There are three ACL modes; auto, system and manual mode. The auto mode and system mode are selected by the MODE switch.

When the cartridge is processed one by one without using the magazine, the ACL enters the manual mode automatically regardless of the MODE switch setting.

a. Auto mode

When the UNLOAD command is received, the cartridge is unloaded and ejected into the magazine, then the next cartridge is loaded automatically.

b. System mode

When the UNLOAD command is received, the cartridge is unloaded. To load the next cartridge, the LOAD DISPLAY command issue is needed.

**10.2.2 Magazine operation**

There are two type of magazine; 5-cartridge type and 10-cartridge type.

(1) Handle

This handle is used for carrying the magazine or for setting the magazine into the ACL.

(2) Cartridge locking bar

This locking bar is used for locking the cartridge so that the cartridge does not fall out of the magazine. When the cartridge is set into the magazine, the cartridge is automatically locked by the cartridge locking bar.

(3) Locking release

There are two way to release the lock of the cartridge. When removing the cartridge one by one, pull out the cartridge with pushing the cartridge locking bar. When removing several cartridges at a time, press the lock release button (all cartridge locking bars are pushed). The cartridges can be removed.

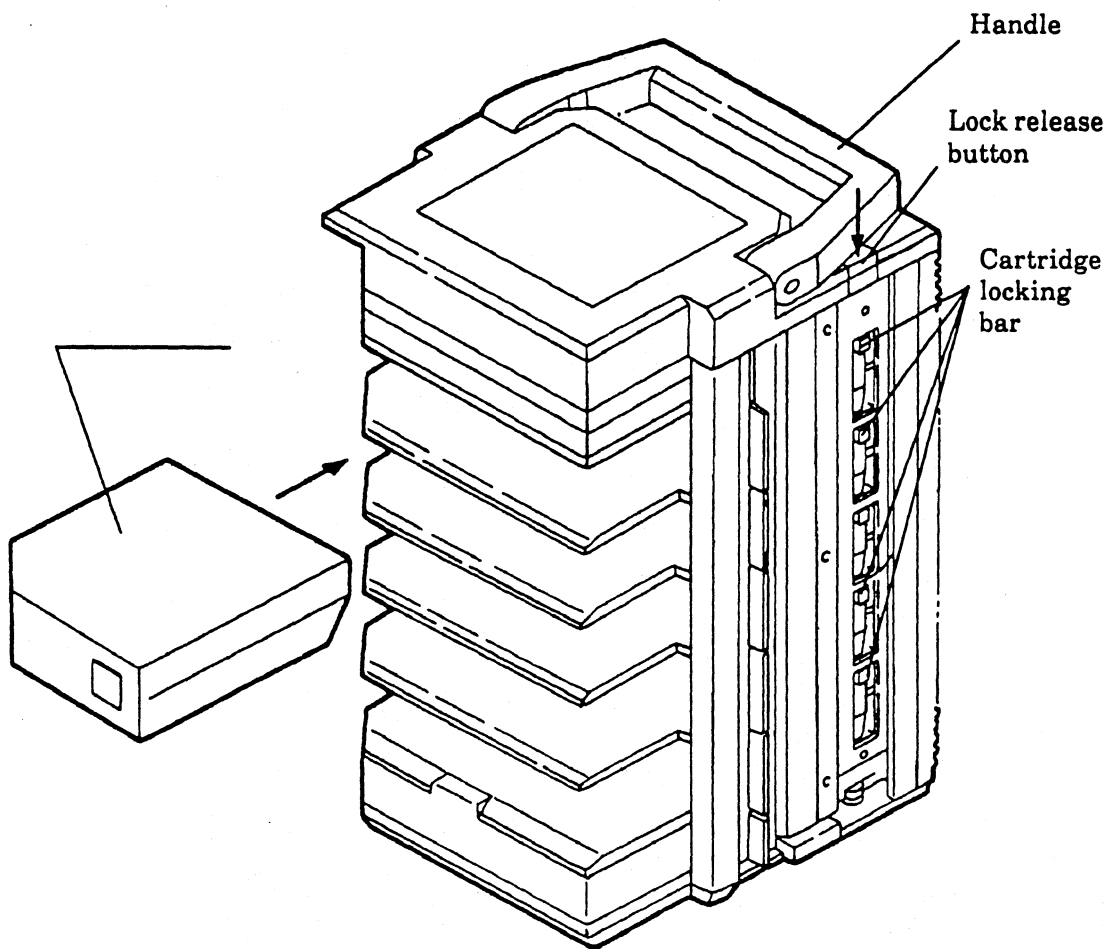

**Figure 10.4 Magazine (5-cartridge type)**

(4) Magazine file protect switch

All cartridges in the magazine are write-inhibited by this switch regardless of each cartridge condition.

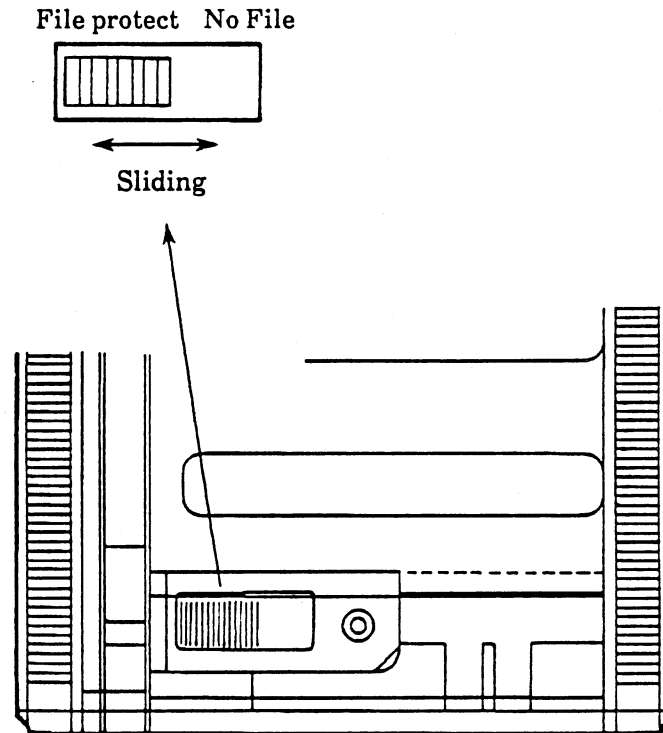

Figure 10.5 Magazine file protect

10.2.3 Notes on use

- ① If a magazine has been placed for a certain period outside the computer room, it must be left in the computer room for the same period (not exceeding 24 hours) before using it.
- ② Do not subject the magazine to dust or high temperatures.
- ③ Do not drop the magazine.
- ④ Protect the magazine from shock.

#### 10.2.4 Notes on storage

Store cartridges under the following environmental conditions.

Temperature:	0 to 50°C (22 to 24°C)
Humidity:	8 to 95%RH (50 to 55%)
Maximum wet bulb temperature:	27°C

#### Notes:

1. Do not store the magazine for more than three months under maximum temperature and humidity.
2. The recommended temperature and humidity are enclosed in parentheses.

#### 10.2.5 Notes on transportation

Transportation environmental conditions are given below. The magazine must be transported within 10 days. The magazine exposed to extremely high temperature (e.g., left in a car) may deform.

	Packaged condition
Temperature	-40 to 60°C
Humidity	5 to 95%RH
Maximum wet bulb temperature	27°C

### 10.2.6 Labels on magazine

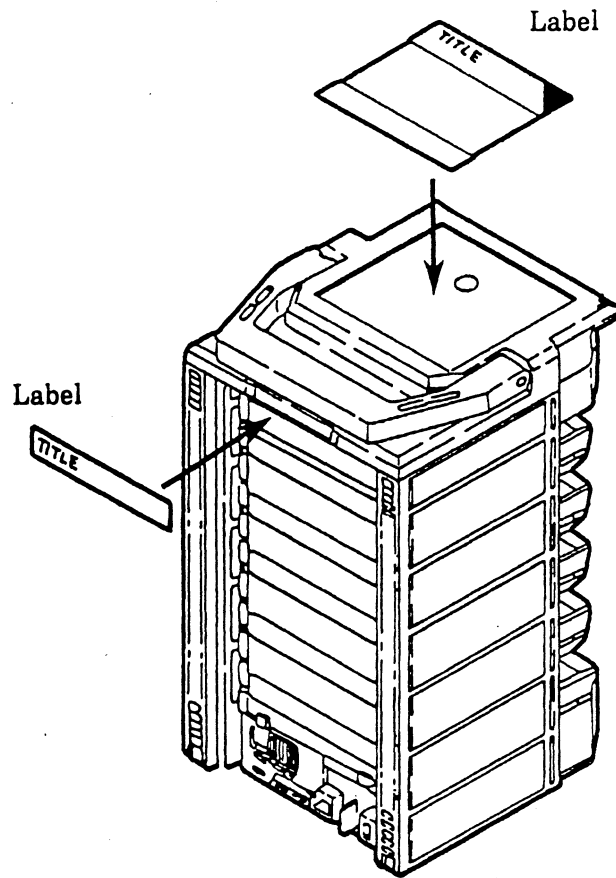
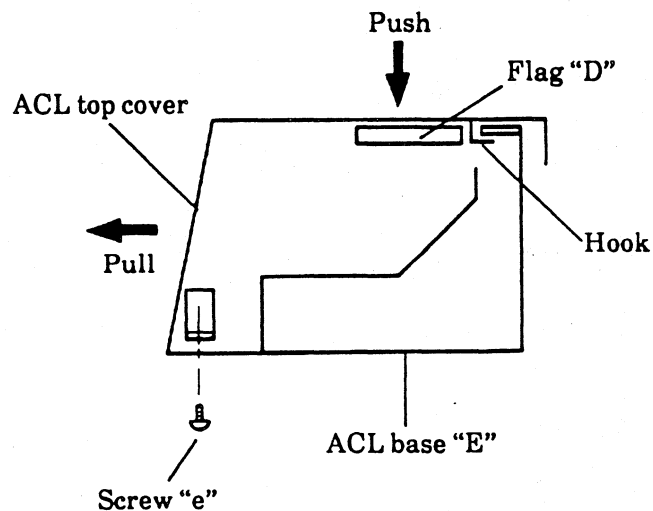

Figure 10.6 Labels position on magazine

### 10.3 Installation Procedure

- (1) Turn off the main switch of the drive and remove the MTU (and connected cables) from the drive.
- (2) Remove the front panel for the MTU with the following procedure (refer to Figure 10.7).
  - ① Remove four screws "a" for the front panel.
  - ② Disconnect one connector of the front panel.
  - ③ Remove two screws "b" and remove the top cover "A".
  - ④ Remove the shaft "C".
  - ⑤ Remove screws "c" and remove the panel bracket "B".
  - ⑥ Mount the FG cable to the original position.
- (3) Mount the ACL with the following procedure.
  - ① Take out the ACL from the packaging box.
  - ② Remove two screws "e" for the ACL top cover. (Refer to Figure 10.8)
  - ③ Pull the ACL top cover this side with pushing the flag "D" with your finger, when the hook is disconnected, lift up the ACL top cover and remove it.



- ④ Remove four screws "F" for the ACL base "E" and remove the ACL mechanism of the ACL from the ACL base "E" (refer to Figure 10.8).

**Note:**

When removing the ACL mechanism from the ACL base, take care not damage the PCA.

- ⑤ Insert the grounding plate "F" (accessory) inside the outer frame of the portion of the front panel of the MTU is removed (meet three holes of the grounding hole to the screw hole of the MTU). (refer to Figure 10.9).

**Note:**

Pass the connector of the operator panel through the cable hole.

- ⑥ Mount the ACL base "E" to the MTU. At that time, put the bolt "g" in the most bottom side (left side) hole of the ACL base at first and tighten the wrench temporarily. Then tighten remaining two screws "g" temporarily. (refer to Figures 10.8 and 10.9).
- ⑦ Run "X" side of the ACL base "E" against "T" side of the MTU side (loader) and run "Y" side of the ACL base "E" against "S" side of the MTU and then tighten three bolts "g" certain. (refer to Figure 10.9).
- ⑧ Connect the operator panel cable "H" (accessory: approximately 30 cm) to the cable "G" from the cable hole of the ACL base "E" (refer to Figure 10.9).
- ⑨ Peel off protect sheet of the adhesive tape inside the ACL base "E" and paste the operator panel cable. (see below).

**Note:**

Mount the operator panel cable "H" inside the ACL base under the condition that the connector of the operator panel cable "H" that is connected to the cable "G" is pushed into the cable hole of the ACL base "E".

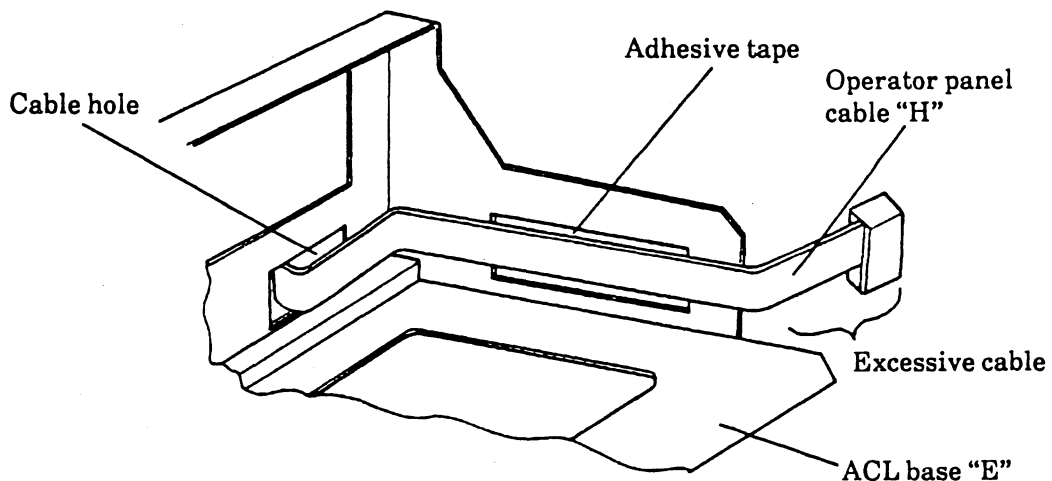

- ⑩ Connect the interface cable "I" (accessory: approximately 10 cm) to the connector "J" of the ACL. (refer to Figure 10.10).
  - ⑪ Mount the ACL mechanism to the ACL base "E" (when mounting take care not damage the PCA).
  - ⑫ Connect the interface cable "I" to the connector "K" of the MTU (refer to Figure 10.11).
  - ⑬ Connect the connector of the operator panel cable "H" to the connector of the ACL. Put the excessive cable in the ACL.
  - ⑭ Mount the ACL top cover (refer to Figure 10.11).
    - (1) When mounting the ACL top cover take care not to pinch cables.
    - (2) Refer to step (3) for the hinge of the ACL top cover. Place the ACL top cover on the ACL base with shifting to the front slightly. Push in the ACL top cover with pushing the flag "D" and hang the edge of the ACL base to the hook of the ACL top cover.
    - (3) Tighten two screws "e" for the ACL top cover.
  - ⑮ Mount the top cover "A" and tighten two screws.
- (4) When the ACL is installed, the EC level setting of the MTU is needed. This setting is made at "71:S.ECL" of display. For setting method, see Section 5.2.

Setting: "EC LV:01" (default: "EC LV:00")

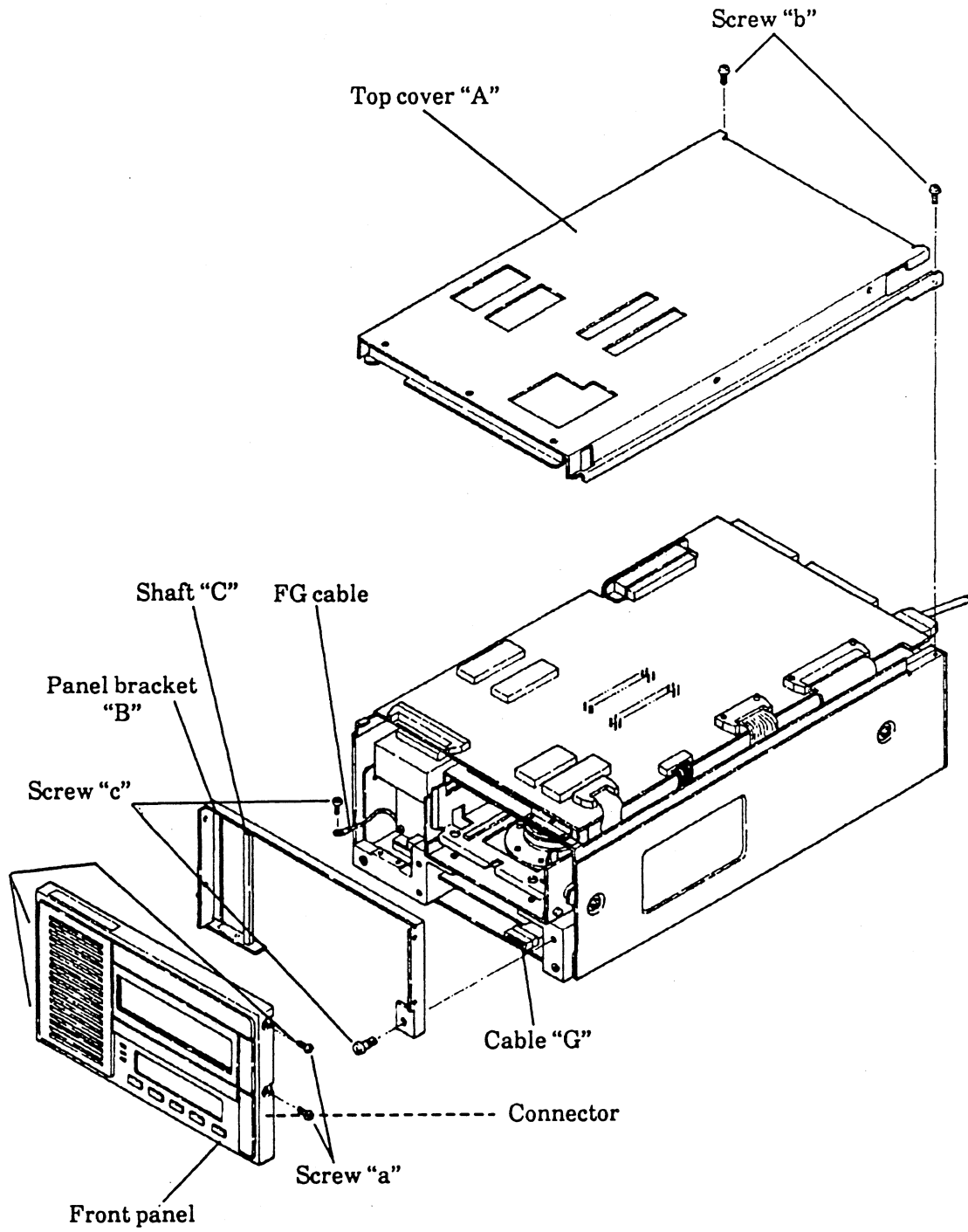

**Figure 10.7 ACL installation (2)**

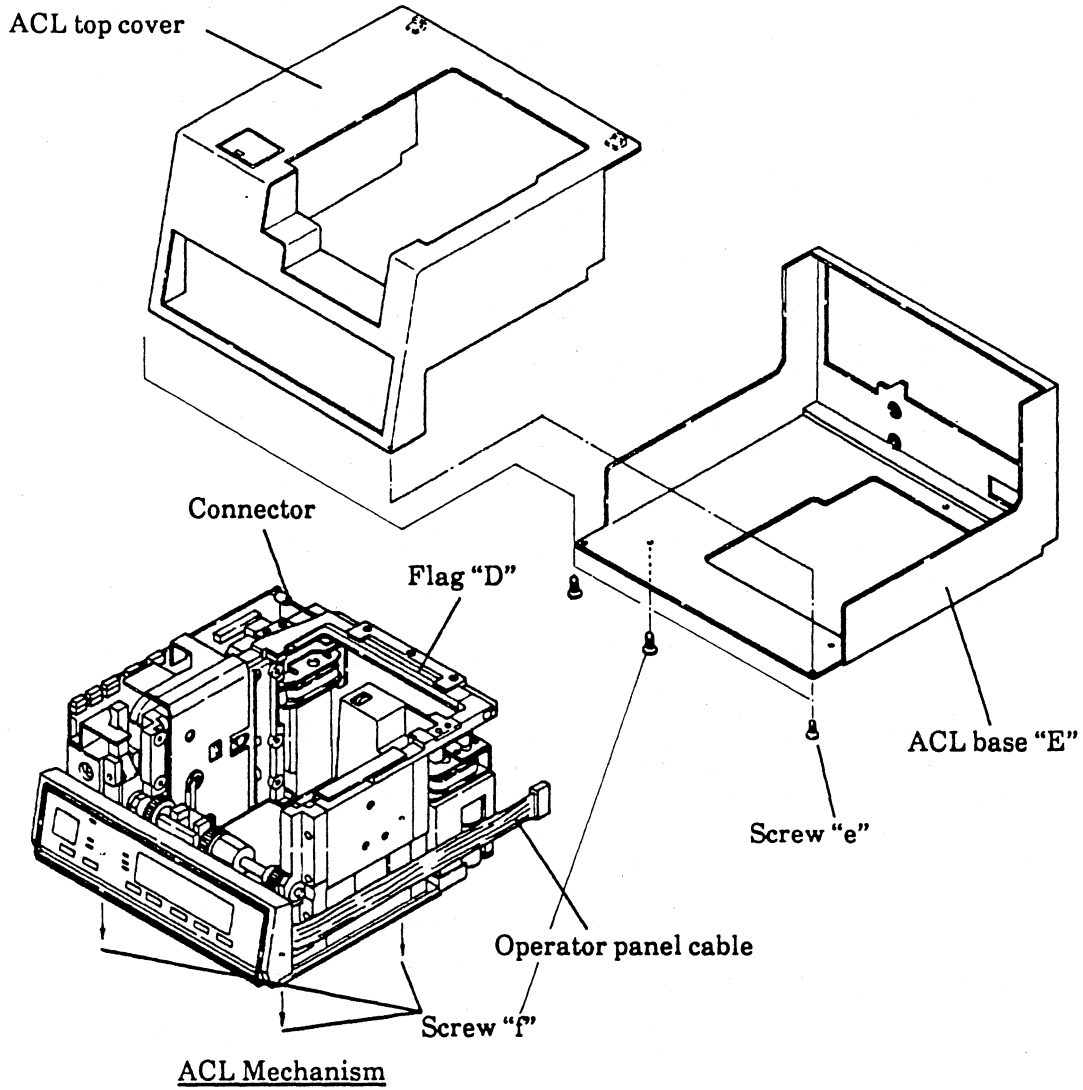

Figure 10.8 ACL installation (3)

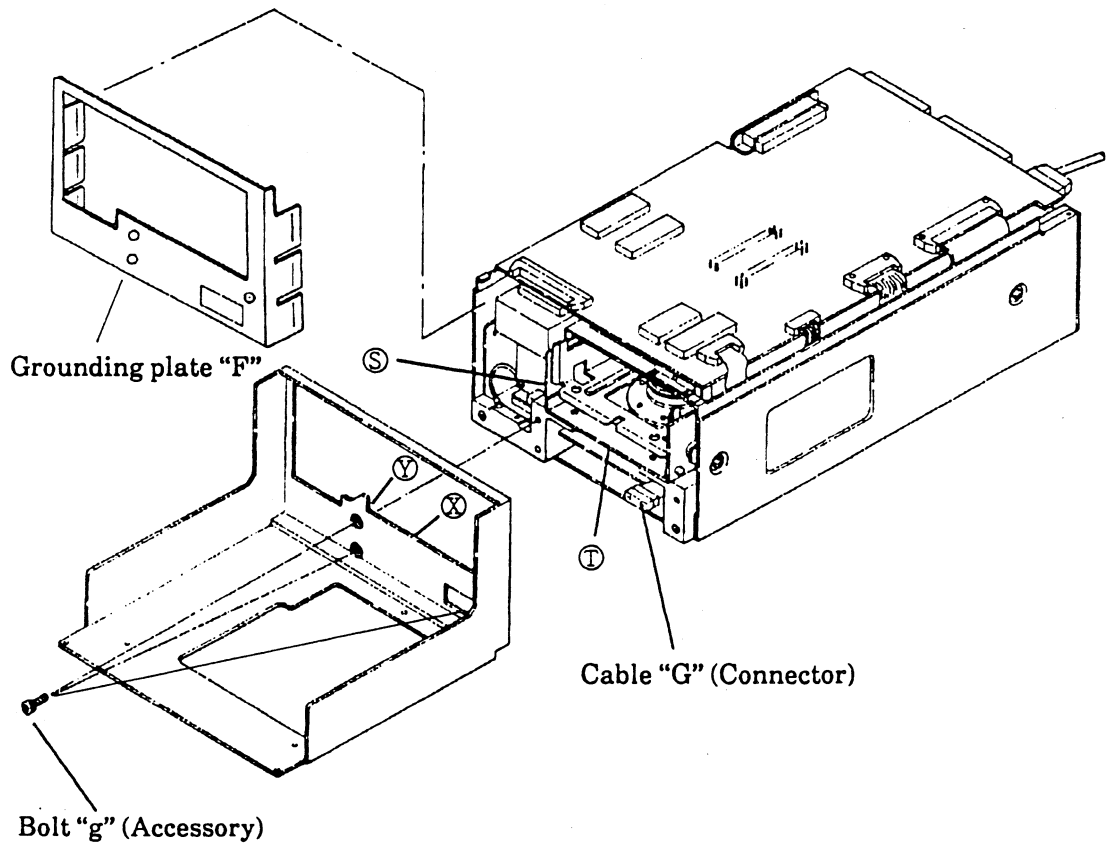
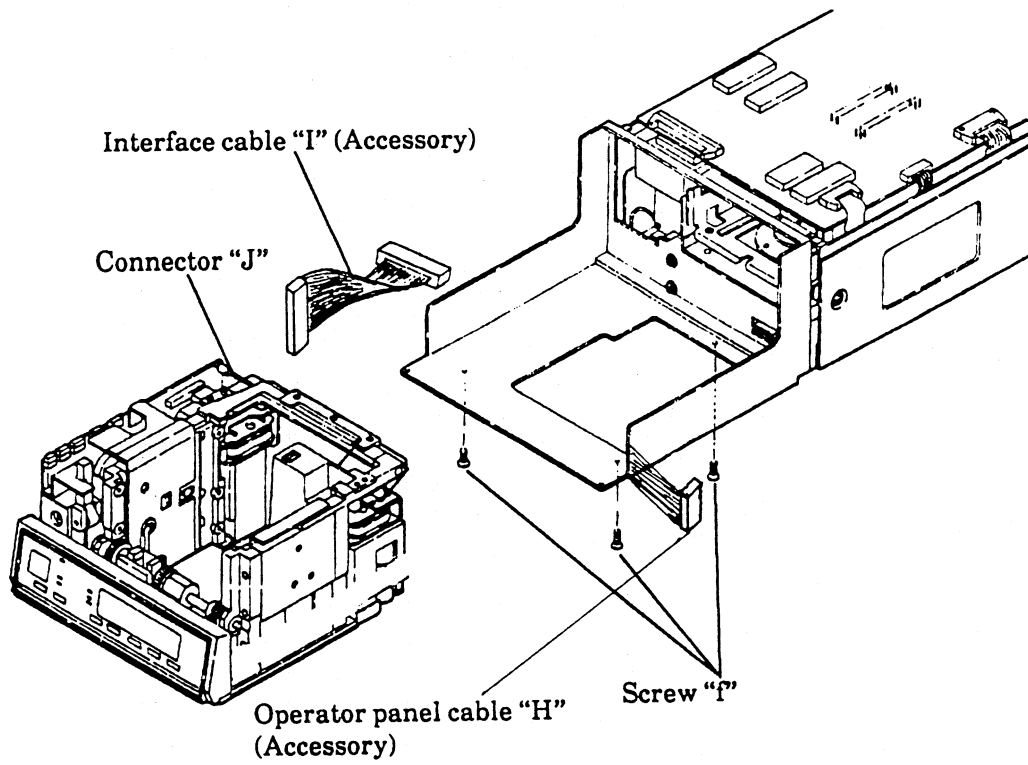

Figure 10.9 ACL installation (4)



**Figure 10.10 ACL installation (5)**

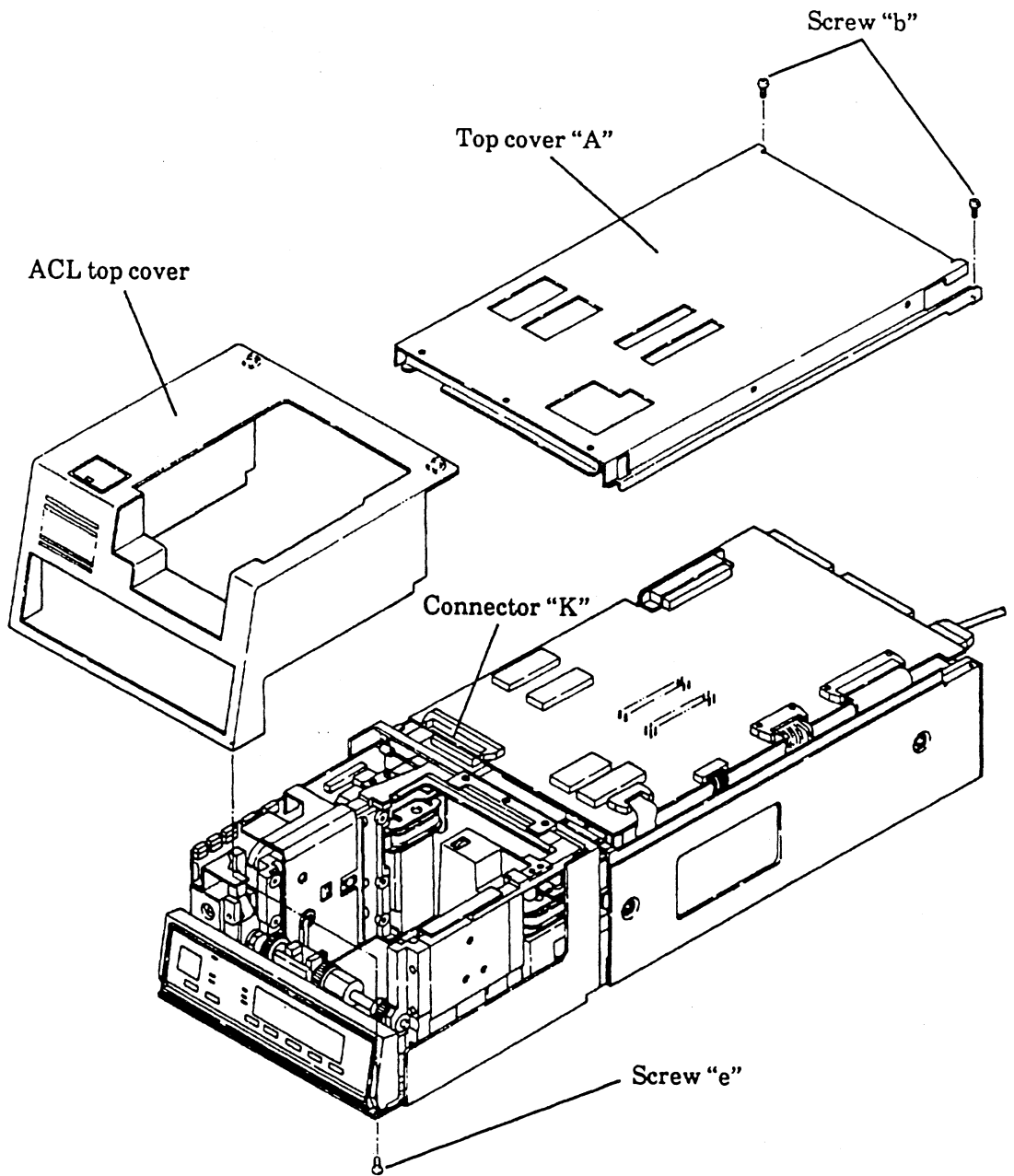

Figure 10.11 ACL installation (6)

**This page is intentionally left blank.**

# Appendix C

## ACL Upgrade Procedures

This appendix describes how to add an ACL to an existing peripheral cabinet.

### C.1 Installation onto Existing Cartridge Tape Drive

This section gives the procedure for installing an ACL onto an existing cartridge tape drive.

#### NOTE

The following items must be taken into consideration before installing an ACL onto an existing cartridge tape drive:

- There can be a maximum of two cartridge tape drives with ACLs in one expansion cabinet.
- Once the ACL is installed, the cabinet door cannot be opened as long as there is a magazine in the ACL. You must make sure devices in the cabinet do not need regular access while the ACL is loaded.
- You must arrange the devices in the peripheral cabinet in a specified order for the formatter, drive, and ACL to fit properly when door is closed. You may have to rearrange and/or remove devices within the cabinet prior to installing the ACL. Refer to the appropriate service guide for instructions on moving devices other than the 3480 tape subsystem. The procedure for removing and rearranging the 3480 formatter and tape drive is described in the remainder of this appendix. This procedure must be executed in the order listed for optimal accessibility and ease of replacement. Figure C-1 shows the required arrangement.

Figure C-1, Required Cabinet Arrangement for ACL Use

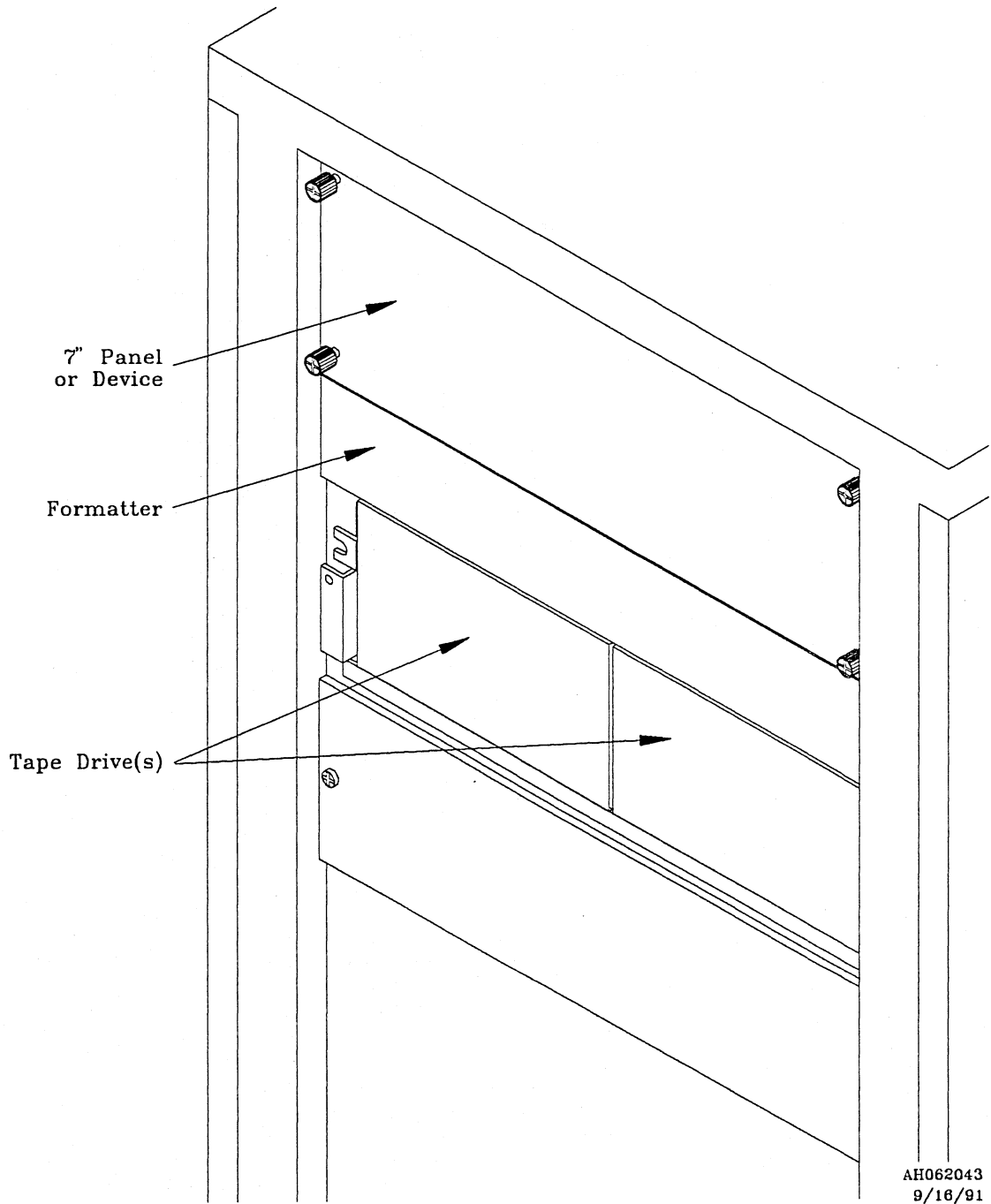

The recommended procedure is:

1. Perform preinstallation procedures (shut down the system, remove power to the expansion cabinet, extend stabilizer bars, and remove cabinet front door).
2. Remove tape drive and formatter.
3. Attach ACL to tape drive.
4. Install new front door.
5. Install apron onto tape drive.
6. Reinstall devices into cabinet.
7. Perform postinstallation procedures (retract stabilizer bars and return power).

The following sections explain these procedures in detail. If your devices are already in this arrangement, refer to Appendix B for instructions on installing the ACL unit.

### C.1.1 Preinstallation

Perform the following steps before installing the ACL onto an existing 3480 tape drive.

**CAUTION**

Shut down system before removing power to the existing expansion cabinet. Failure to do so will cause a system crash and possible loss of data.

1. Shut down the system. Refer to the *Managing ConvexOS: Operations Guide* for power-down procedures on a CONVEX supercomputer.
2. Turn the processor's front panel key switch to the *OFF* position. Figure C-2 shows a typical front panel control switch:

**Figure C-2, C200 Series Front Panel Power Control Switch**

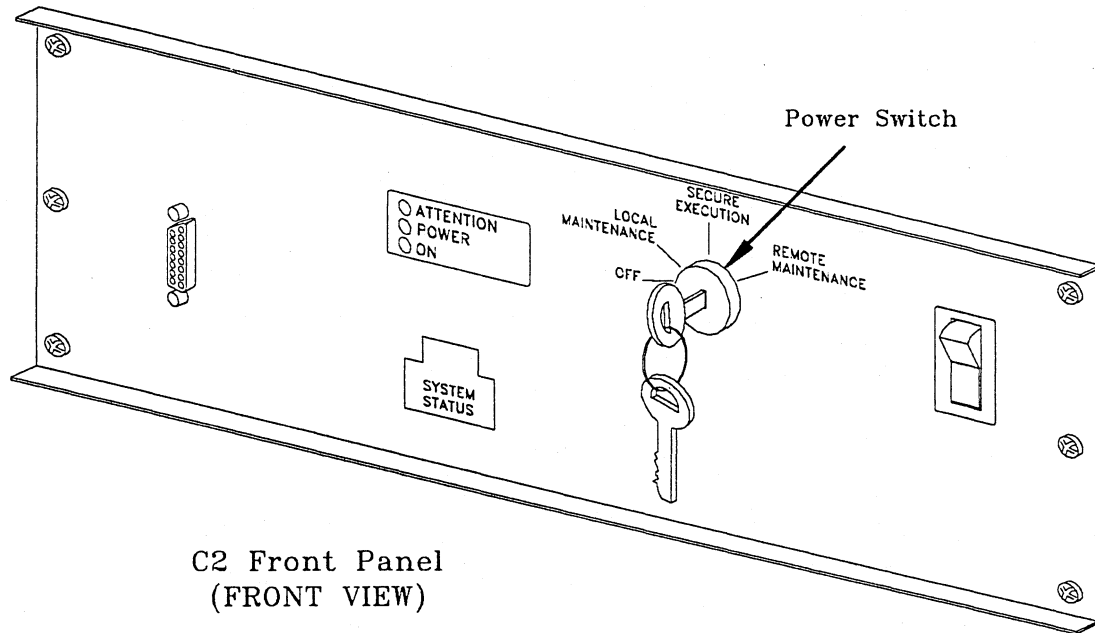

**C2 Front Panel  
(FRONT VIEW)**

AH062014  
9/4/91

**CAUTION**

Remove power to the peripheral expansion cabinet before installing or removing equipment. Failure to do so will damage electronic equipment components.

3. Remove power to the expansion cabinet.

- To remove power from a CONVEX EXP-101 or EXP-102 expansion cabinet, disconnect the AC power cord from the AC power source.
- To remove power from a CONVEX EXP-105 or later high-performance expansion cabinet, set the main power control switch to the **OFF** position. Figure C-3 shows the EXP-105 expansion cabinet's power controller front panel and main power control switch:

Figure C-3, EXP-106 Expansion Cabinet Power Controller Front Panel

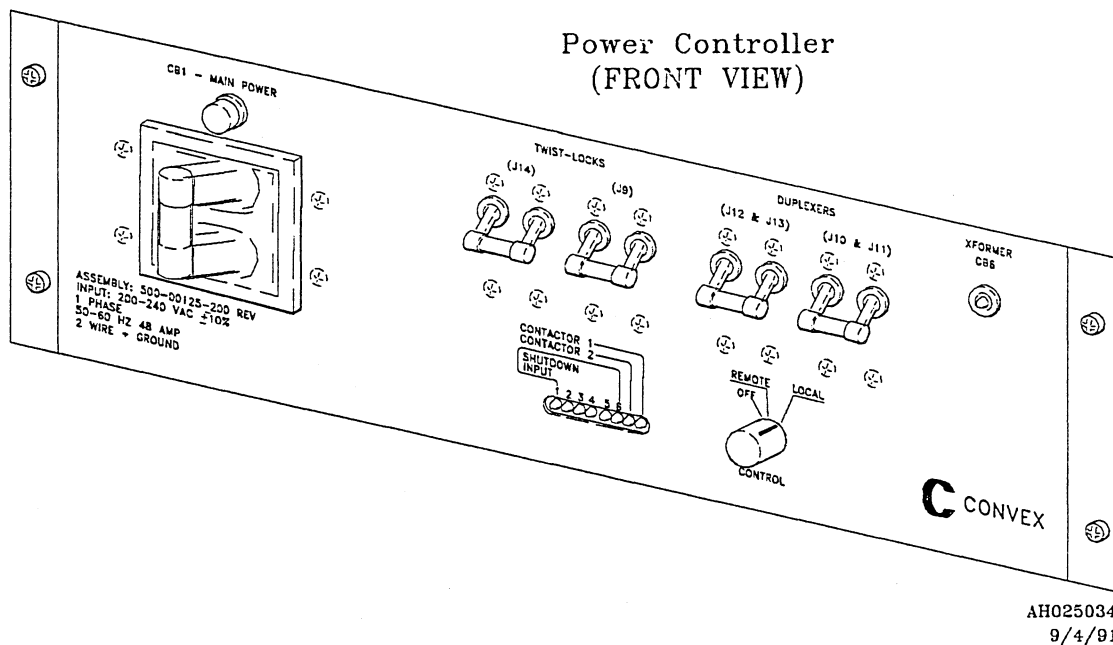
**WARNING**

Expansion cabinet stabilizer bars must be extended before extending the cartridge tape drive assembly from its expansion cabinet for service. Failure to do so will make the expansion cabinet unstable, increase the possibility of it falling forward, can cause injury to personnel, and will cause damage to equipment.

4. Extend the expansion cabinet stabilizer bars and adjust the feet until they are in firm contact with the floor. Figure C-4 shows the expansion cabinet stabilizer bars and adjustable feet:
5. Unless you have an EXP-106 expansion cabinet, remove the existing front door to the expansion cabinet.

Figure C-4, Expansion Cabinet Stabilizer Bars

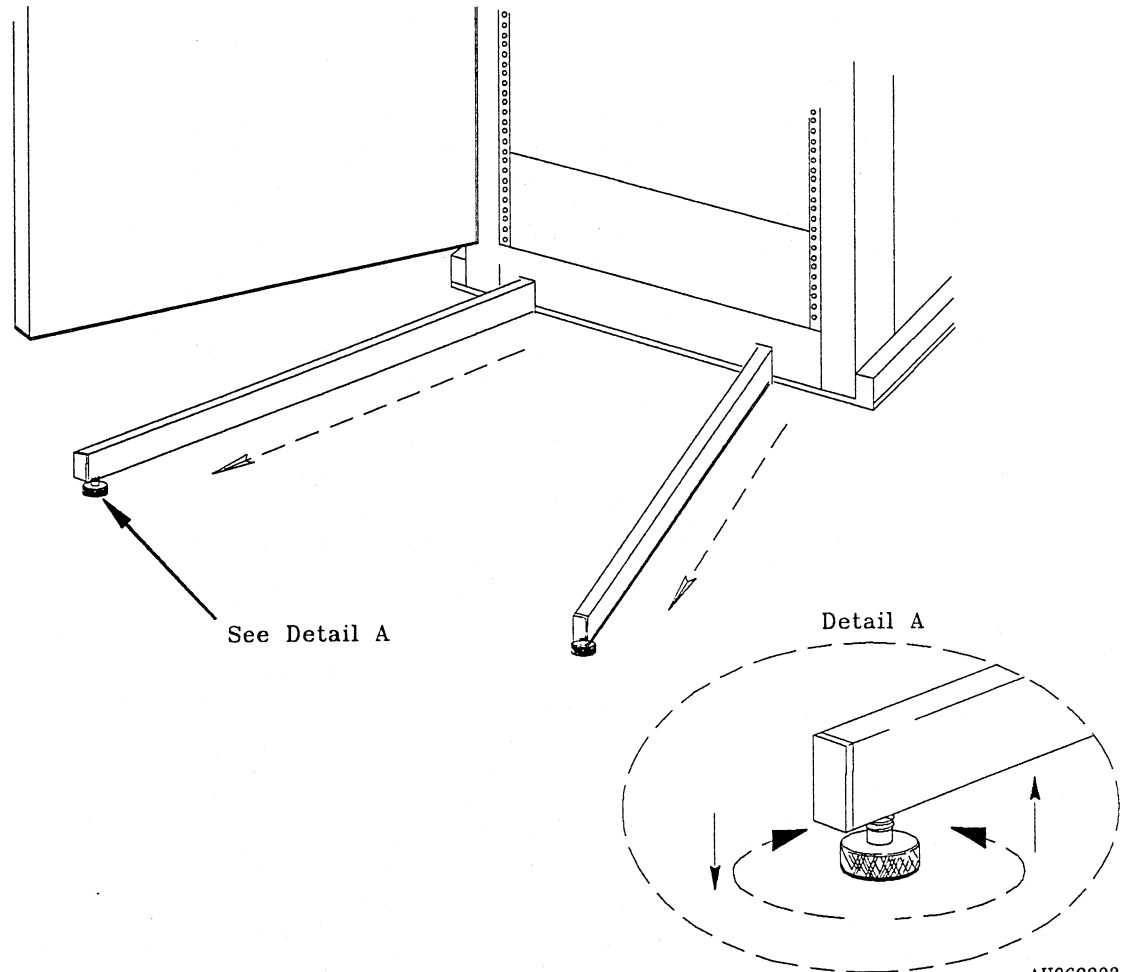

AH060003  
9/4/91

## C.1.2 Removal of Existing Devices

This section gives procedures for removing existing tape devices in a CONVEX expansion cabinet before installing the ACL onto the existing 3480 tape drive.

### C.1.2.1 Formatter Removal

1. Mark all cables connected to the rear of the formatter for easy reconnection.
2. Disconnect the power cable, the PCI cable, the MTU DIGITAL cable, the MTU ANALOG cable, the SCSI IN, and the SCSI OUT cable from the rear of the formatter.
3. Slide the formatter out of the cabinet.

### C.1.2.2 Tape Drive Removal

Perform the following procedure to remove each tape drive.

**NOTE**

To avoid injury, remove the tape drive(s) from the tray while the tray is in the forward, locked position.

To avoid injury and to make the ACL attachment easier, place the tape drive(s) on a workbench.

1. Disconnect the appropriate tape drive's power cord from the power strip.
2. Remove the 2 screws holding the cartridge tape drive tray and slide the tray partially out of the cabinet.
3. Remove the 2 screws securing the shielding bracket covering the cables and remove the shielding bracket.
4. Mark each cable attached to the tape drive for easy replacement.
5. Remove each cable attached to the tape drive. Remove the terminator from the tape drive (if present).
6. Remove the 2 screws that secure the cable shielding clamp to the tape drive.
7. Remove the 4 screws from the bottom of the tray holding the target tape drive.
8. Remove the tape drive.

## C.1.3 ACL Installation

Install the ACL unit. Refer to Appendix B of this guide for installation procedures.

### C.1.4 Replacement of Existing Devices

This section give steps for replacing devices into a CONVEX expansion cabinet after installing the ACL onto a 3480 tape drive.

1. If you are leaving another device in the top of the cabinet, ensure that it is exactly 7 inches from the top. Otherwise, install a filler panel (CONVEX part number 320-000239-503) as a spacer.
2. Install the formatter chassis with the top exactly 7 inches below the top of the cabinet, underneath the previous device or panel. Different formatters have different hole placements, so make sure the top of the chassis is placed exactly 7 inches below the top of the cabinet.
3. Install the tape cartridge rackmount rails directly below and flush against the bottom of the formatter chassis (no empty holes between them), exactly 3-1/2 inches below filler panel or device.
4. Install the extender brackets for the tape drive. Refer to Figure C-5 for placement of screws and clipnuts.

**NOTE**

The screwholes for the bracket must align with those on the rackmount rails, so you may want to set the tray in the rails temporarily for alignment purposes.

**Figure C-5, Extender Bracket Installation**

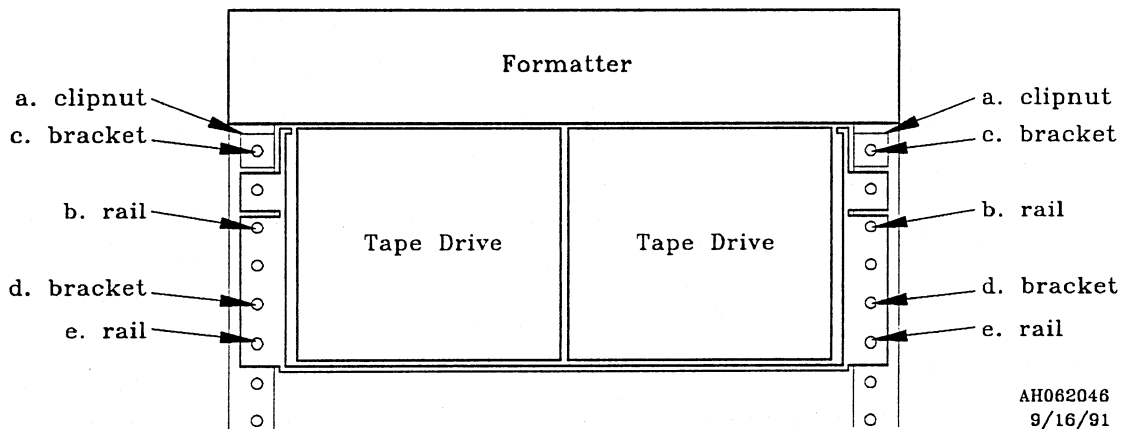

- a. Install a clipnut into the top hole in the RETMA rail.
  - b. Install the top screw that holds the rackmount rails on the RETMA rail.
  - c. Install a screw through the top hold in the extender bracket into the clipnut mounted in step a.
  - d. Install the bottom screw of the extender bracket in the hole that is second from the bottom in the rackmount rail.
  - e. Install the bottom screw attaching the rackmount rails onto the RETMA rail.
5. Install tape drive tray, with power supply, on the extender bracket as shown in Figure C-6.

**Figure C-6, Tape Drive Installation Onto Bracket**

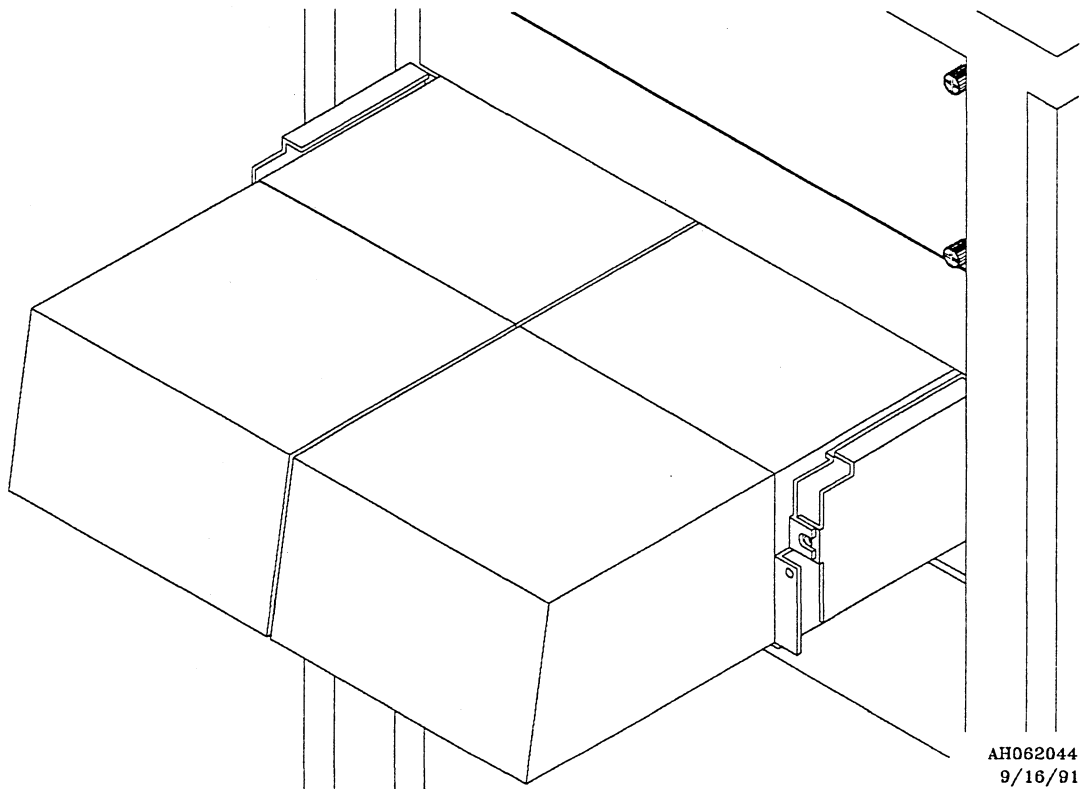

6. Install tape drive onto tray.
  - a. Place the tape drive in the tray.
  - b. Install the 4 screws into the bottom of the tray that holds the tape drive.

**NOTE**

Refer to Chapter 2, "Unpacking and Installation," section 2.3.4.1, "Installation of the Cartridge Tape Drive and Power Supply," for more detailed instructions on cabling.

- c. Install the 2 screws that secure the cable clamp bracket to the tape drive.
  - d. Attach the cables and terminator (if necessary) to the tape drive.
  - e. Install the shielding bracket over the cable clamp bracket and secure with 2 screws.
  - f. Slide the tape drive tray back into the expansion cabinet.
  - g. Install the 2 screws that hold the tray in the expansion cabinet.
7. If you have removed the cabinet front door, install the new front door on the expansion cabinet.
8. Install the apron over the tape drive unit, as shown in Figure C-7.

**NOTE**

The door must be open at a 90-degree angle to avoid bending the apron.

If the cabinet contains only one tape unit with ACL, place that unit on the left as you face the cabinet.

If there is only one tape unit in the cabinet, place that unit on the left as you face the cabinet. Install a filler panel underneath the apron on the right-hand side, using the holes in the top of the apron.

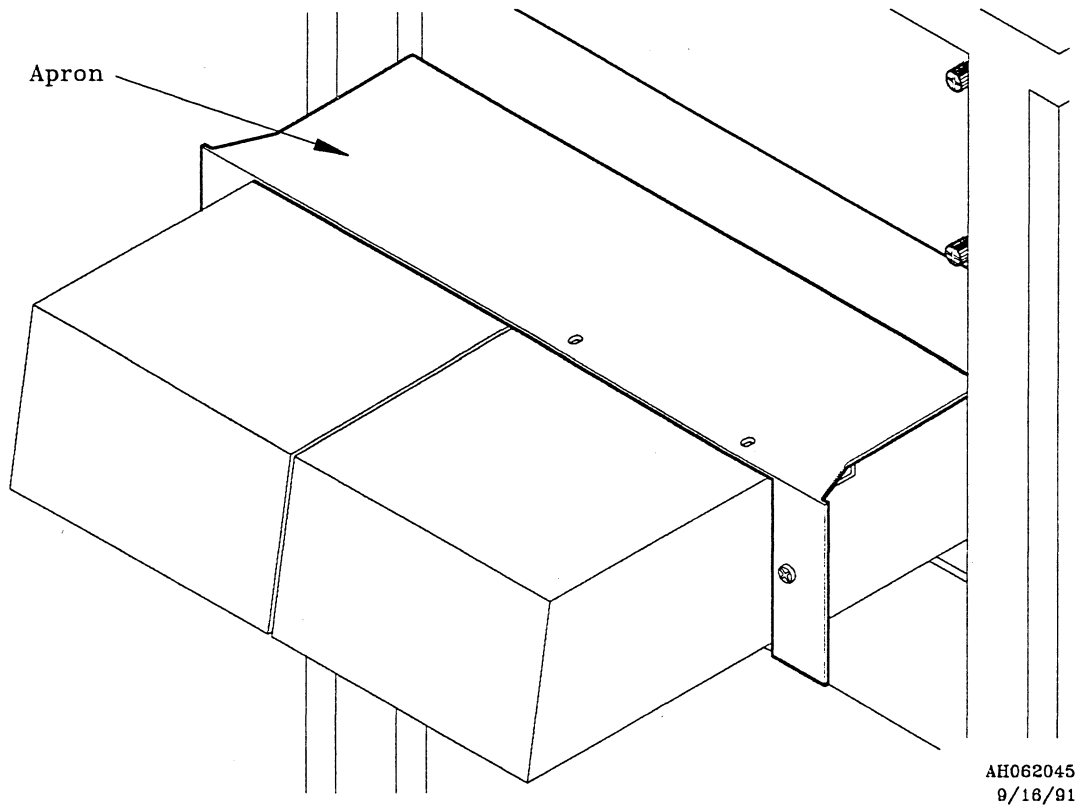
**Figure C-7, Tape Drive Apron**

9. Install formatter into chassis.
10. Connect the power cable, the **PCI** cable, the **MTU DIGITAL** cable, the **MTU ANALOG** cable, the **SCSI IN**, and the **SCSI OUT** cable to the rear of the formatter.

Figure C-8 illustrates the new cabinet arrangement with the ACL attached.

Figure C-8, Cabinet with ACL Installed

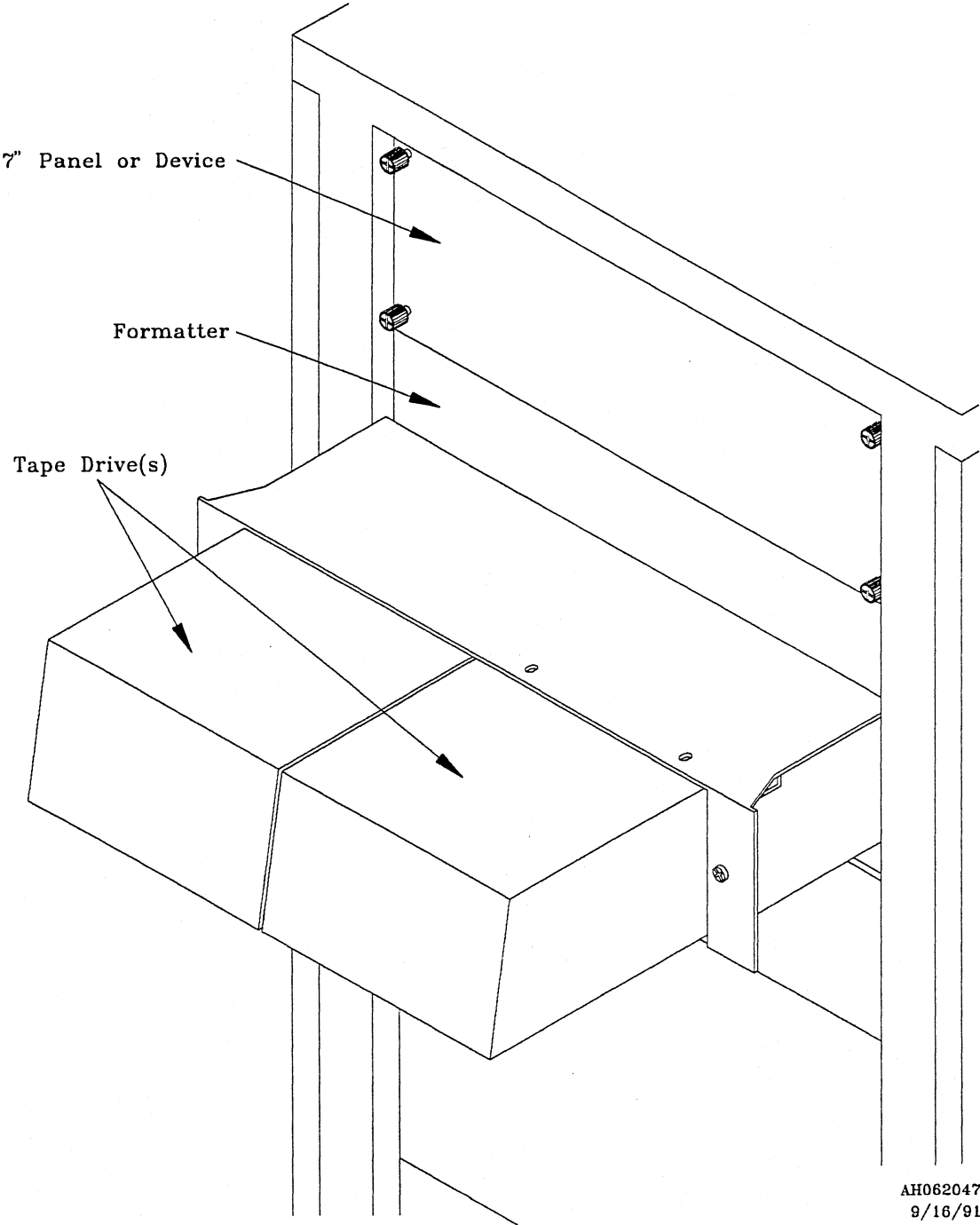

### C.1.5 Postinstallation

Perform the following steps after replacing devices into the expansion cabinet.

1. Retract the expansion cabinet stabilizer bars. See Figure C-4.
2. Restore AC power to the expansion cabinet.
  - To restore AC power to a CONVEX EXP-101, EXP-102, or EXP-302 expansion cabinet, connect the cabinet's AC power cord to the AC power source.
  - To restore AC power to a CONVEX EXP-105 or equivalent high-performance expansion cabinet, set the cabinet's main power switch to the ON position.
3. Set the processor's front panel key switch to the ON position. See Figure C-2.

## C.2 Part Number List

Table C-1 lists CONVEX part numbers and descriptions for the FRUs of the ACL:

**Table C-1, ACL Parts List**

Part Number	Description
207-000015-032	Cartridge loader, auto 3480
207-000015-036	Magazine, black, 10 cartridge ACL

Table C-2 lists CONVEX part numbers and descriptions for the expansion cabinet door assembly:

**Table C-2, Cabinet Door Parts List**

Part Number	Description
500-001030-200	PUR ASSY, PERIPH DOOR 3480 ACL, LEFT-HAND
500-001030-201	PUR ASSY, PERIPH DOOR 3480 ACL, RIGHT-HAND
330-000207-500	PFAB, PANEL INSERT DOOR, ACL

Table C-3 lists CONVEX part numbers and descriptions for the extender bracket installation kit:

**Table C-3, Extender Bracket Kit Parts List**

<b>Part Number</b>	<b>Description</b>
501-000150-200	KIT, EXTENDER, ACL 3480 DR
320-002457-500	MFAB, APRON ACL (3480)
320-002406-500	MFAB, SPACER, ACL (3480) R HD
320-002406-501	MFAB, SPACER, ACL (3480) L HD
310-005104-001	SCR, 8-32X1/2, PHH, PNH, BL OX
310-150503-001	NUT, 10-32, CLIP
320-002458-500	MFAB, FILLER PANEL ACL (3480)

# Index

## A

- AC power cable, power supply, illustrated 2-16
- AC power cable, power supply, installation, discussed 2-15
- ACL. *see* Automatic Cartridge Loader B-1
- ACL, installation, discussed B-1, C-1
- Air filter, tape drive, removal/replacement, discussed 4-6
- Altitude, operating, cartridge tape, chart 1-6
- Altitude, operating, formatter, chart 1-7
- Analog cable, MTU, cabling, formatter, discussed 2-23
- Associated documents, listed xi
- audience, of *CONVEX 3480-Compatible Cartridge Tape Service Guide* ix
- Automatic Cartridge Loader (ACL) B-1
- Automatic Cartridge Loader (ACL), field upgrade procedures C-1
- Automatic Cartridge Loader (ACL), installation B-1, C-1
- Automatic Cartridge Loader (ACL), specifications B-1

## B

- Bibliography. *See* Associated documents
- Board, CR, tape drive, removal/replacement, discussed 4-6
- Board, PC, formatter, removal/replacement, discussed 4-8
- Board, PC, removal tool, formatter, discussed 4-8
- Bracket, shield, installation, discussed 2-12
- Bracket, shield, tape drive, illustrated 2-12

## C

- C200 Series front panel power control switch, illustrated C-3
- C200 Series power control switch, front panel, illustrated C-3
- Cabinet, installation, discussed 2-2
- Cabinet rearrangement, illustrated C-1, C-12
- Cable, 2-23
- Cable, DC, power supply, illustrated 2-12
- Cable IPB, tape system, illustrated 4-11
- Cable list, tape system, chart 4-10
- Cable, MTU digital, formatter, illustrated 2-23
- Cable, SCSI host adapter, maximum length, discussed 2-4
- Cable, SCSI IN, installation, formatter, discussed 2-25
- Cable, SCSI OUT, installation, formatter, discussed 2-25
- Cable shielding clamp, illustrated 2-8, 2-10, 2-11
- Cable shielding clamp, installation, discussed 2-8
- Cable shielding clamp, strain relief, illustrated 2-8, 2-10, 2-11
- Cabling, daisy chain, formatter, discussed 2-25
- Cabling, daisy chain, formatter, illustrated 2-25
- Cabling, DC power cable, discussed 2-12
- Cabling, MTU analog cable, formatter, discussed 2-23
- Cabling, MTU digital cable, formatter, discussed 2-23
- Cabling, PCI/PCO, discussed 2-26
- Cabling, PCI/PCO, illustrated 2-27
- Cabling, tape drive, discussed 2-14
- Cabling, tape drive, formatter, illustrated 2-23
- Cabling, tape drive, illustrated 2-14
- Capacity, storage, discussed 1-1
- Cartridge tape, depth, chart 1-6
- Cartridge tape, height, chart 1-6
- Cartridge tape, humidity change, chart 1-6
- Cartridge tape, humidity range, chart 1-6
- Cartridge tape, illustrated 1-3
- Cartridge tape, installation, discussed 2-8
- Cartridge tape, noise, chart 1-6
- Cartridge tape, operating altitude, chart 1-6
- Cartridge tape, overview, discussed 1-3
- Cartridge tape, specifications, chart 1-6
- Cartridge tape system, configuration, discussed 2-2
- Cartridge tape, temperature change, chart 1-6
- Cartridge tape, temperature range, chart 1-6
- Cartridge tape, voltage, chart 1-6

- Cartridge tape, weight, chart 1-6
- Cartridge tape, width, chart 1-6
- Cautions, described xi
- Claims, damage, reporting 2-3
- Clamp, cable shielding, illustrated 2-8, 2-10, 2-11
- Cleaning, tape drive, discussed 4-1
- Configuration, cartridge tape system, discussed 2-2
- Configuration, ConvexOS, discussed 3-1
- Configuration, formatter, DI card dip switches, discussed 2-19
- Configuration, system, discussed 1-1
- ConvexOS, V8.1, discussed 3-1
- ConvexOS, V9.0 or later, discussed 3-1
- CR board, tape drive, removal/replacement, discussed 4-6

## D

- Daisy chain cabling, formatter, discussed 2-25
- Daisy chain cabling, formatter, illustrated 2-25
- Daisy chain cabling, tape drives, discussed 2-14
- Damage, inspection, discussed 2-2
- Damage, shipping, reporting 2-3
- DC power cable, installation, discussed 2-12
- DC power cable, power supply, installation, discussed 2-12
- DC power cable, tape drive, illustrated 2-12
- DC power cable, tape drive, installation, discussed 2-12
- Depth, cartridge tape, chart 1-6
- Depth, formatter, chart 1-7
- dev\_v8480* diagnostic, tape system, discussed 3-3
- DI card, dip switches, formatter configuration, discussed 2-19
- DI card, dip switches, formatter, illustrated 2-19
- Diagnostic, *dev\_v8480*, tape system, discussed 3-3
- Diagram, system, illustrated 1-1
- Digital cable, MTU, cabling, formatter, discussed 2-23
- Dip switch, SW1, configuration, formatter, chart 2-21
- Dip switch, SW2, configuration, formatter, chart 2-21
- Dip switches, DI card, formatter configuration, discussed 2-19
- Dip switches, DI card, formatter, illustrated 2-19
- Documentation, ordering xii

## E

- ESD, causes of, discussed 2-1
- ESD charge levels, defined 2-1
- ESD component damage, voltage levels, defined 2-1
- Existing cabinet, installation, discussed 2-2
- Existing tape drive, addition of ACL, discussed C-1
- EXP-105 or equivalent power controller, illustrated 2-5
- EXP-106, power controller, illustrated C-4
- Expansion cabinet power controller, illustrated 2-5, C-4
- Expansion cabinet stabilizer bars, illustrated 2-6, 4-3, C-5
- Expansion cabinet, system configuration, discussed 2-2

## F

- Fan, formatter, removal/replacement, discussed 4-8
- Filter maintenance, tape drive, discussed 4-2
- Filter, vane pump, tape drive, removal/replacement, discussed 4-6
- Formatter configuration, DI card dip switches, discussed 2-19
- Formatter, daisy chain cabling, discussed 2-25
- Formatter, daisy chain cabling, illustrated 2-25
- Formatter, depth, chart 1-7
- Formatter, DI card dip switches, illustrated 2-19
- Formatter, fan, removal/replacement, discussed 4-8
- Formatter, height, chart 1-7
- Formatter, humidity change, chart 1-7
- Formatter, humidity range, chart 1-7
- Formatter, illustrated 1-5
- Formatter, installation, discussed 2-19

## Index

Formatter, internal tests, discussed 3-4  
Formatter mounting frame, installation, discussed 2-21  
Formatter, MTU analog cable, cabling, discussed 2-23  
Formatter, MTU digital cable, cabling, discussed 2-23  
Formatter, OP panel, removal/replacement, discussed 4-8  
Formatter, operating altitude, chart 1-7  
Formatter, overview, discussed 1-4  
Formatter, parts list, chart 4-10  
Formatter, PC board, removal tool, discussed 4-8  
Formatter, PC board, removal/replacement, discussed 4-8  
Formatter, PCI cabling, discussed 2-26  
Formatter, PCI cabling, illustrated 2-27  
Formatter, power supply, removal/replacement, discussed 4-8  
Formatter, power supply voltage jumper, discussed 2-17  
Formatter, power supply voltage jumper, illustrated 2-17  
Formatter, rear mounting brackets, illustrated 2-21  
Formatter, removal/replacement, discussed 4-7  
Formatter, SCSI IN cable, installation, discussed 2-25  
Formatter, SCSI OUT cable, installation, discussed 2-25  
Formatter, specifications, chart 1-7  
Formatter, SW1 dip switch, configuration, chart 2-21  
Formatter, SW2 dip switch, configuration, chart 2-21  
Formatter, tape drive, cabling, illustrated 2-23  
Formatter, temperature change, chart 1-7  
Formatter, temperature range, chart 1-7  
Formatter, terminator, discussed 2-25  
Formatter, voltage range, chart 1-7  
Formatter, weight, chart 1-7  
Formatter, width, chart 1-7  
Front panel power control switch, illustrated 2-4

## H

Height, cartridge tape, chart 1-6  
Height, formatter, chart 1-7  
Host adapter, cable, maximum length, discussed 2-4  
Host adapter, discussed 1-1  
Humidity change, cartridge tape, chart 1-6  
Humidity change, formatter, chart 1-7  
Humidity levels, ESD, relationships 2-1  
Humidity range, cartridge tape, chart 1-6  
Humidity range, formatter, chart 1-7

## I

Inspection, damage, discussed 2-2  
Inspection, unpacking, discussed 2-1  
Installation, ACL, existing tape drive, discussed C-1  
Installation, cable shielding clamp, discussed 2-8  
Installation, cartridge tape drive, discussed 2-8  
Installation, cartridge tape system, discussed 2-3  
Installation, DC power cable, discussed 2-12  
Installation, existing cabinet, discussed 2-2  
Installation, formatter, discussed 2-19  
Installation, formatter mounting frame, discussed 2-21  
Installation, power supply AC power cable, discussed 2-15  
Installation, power supply, discussed 2-8  
Installation, pre-configured cabinet, discussed 2-28  
Installation, SCSI IN cable, formatter, discussed 2-25  
Installation, SCSI OUT cable, formatter, discussed 2-25  
Installation, shield bracket, discussed 2-12  
Integration, software, tape system, discussed 3-1  
Internal tests, formatter, discussed 3-4  
Internal tests, tape drive, discussed 3-3  
*/ioconfig* file, discussed 3-1  
*/ioconfig* file, illustrated 3-1

## J

Jumper, power supply voltage, formatter, discussed 2-17  
Jumper, power supply voltage, formatter, illustrated 2-17

## L

Length, maximum, host adapter cable, discussed 2-4

## M

Maintenance, filter, tape drive, discussed 4-2  
Mounting brackets, rear, formatter, illustrated 2-21  
Mounting frame, installation, formatter, discussed 2-21  
MTU analog cable, cabling, formatter, discussed 2-23  
MTU analog cable, formatter, illustrated 2-23  
MTU digital cable, cabling, formatter, discussed 2-23  
MTU digital cable, formatter, illustrated 2-23

## N

Noise, cartridge tape, chart 1-6  
notational conventions x  
Notes, described xi

## O

OP panel, formatter, removal/replacement, discussed 4-8  
OP panel, tape drive, removal/replacement, discussed 4-6  
Operating altitude, cartridge tape, chart 1-6  
Operating altitude, formatter, chart 1-7  
Operation, ACL, discussed B-1  
Overview, cartridge tape, discussed 1-3  
Overview, discussed 1-1  
Overview, formatter, discussed 1-4

## P

Packing material, saving 2-3  
Panel, OP, formatter, removal/replacement, discussed 4-8  
Panel, OP, tape drive, removal/replacement, discussed 4-6  
Parts list, formatter, chart 4-10  
Parts list, tape drive, chart 4-9  
PC board, formatter, removal tool, discussed 4-8  
PC board, formatter, removal/replacement, discussed 4-8  
PCI/PCO cabling, discussed 2-26  
PCI/PCO cabling, illustrated 2-27  
Power control switch, front panel, illustrated 2-4  
Power controller, expansion cabinet, illustrated 2-5, C-4  
Power supply AC power cable, illustrated 2-16  
Power supply, AC power cable, installation, discussed 2-15  
Power supply, DC power cable, illustrated 2-12  
Power supply, DC power cable, installation, discussed 2-12  
Power supply, formatter, removal/replacement, discussed 4-8  
Power supply, installation, discussed 2-8  
Power supply, PCI/PCO cabling, discussed 2-26  
Power supply, PCI/PCO cabling, illustrated 2-27  
Power supply, removal/replacement, discussed 4-5  
Power supply voltage jumper, formatter, discussed 2-17  
Power supply voltage jumper, formatter, illustrated 2-17  
purpose, of *CONVEX 3480-Compatible Cartridge Tape Service Guide* ix

---

**R**

---

Rear mounting brackets, formatter, illustrated 2-21  
 Removal tool, PC board, formatter, discussed 4-8  
 Removal/replacement, 4-7  
 Removal/replacement, air filter, tape drive, discussed 4-6  
 Removal/replacement, fan, formatter, discussed 4-8  
 Removal/replacement, OP panel, formatter, discussed 4-8  
 Removal/replacement, OP panel, tape drive, discussed 4-6  
 Removal/replacement, PC board, formatter, discussed 4-8  
 Removal/replacement, power supply, discussed 4-5  
 Removal/replacement, power supply, formatter, discussed 4-8  
 Removal/replacement, tape drive, discussed 4-2  
 Removal/replacement, vane pump filter, tape drive, discussed 4-6  
 reporting problems xii  
 Revision sheet 3

---

**S**

---

SCSI host adapter, cable, maximum length, discussed 2-4  
 SCSI host adapter, discussed 1-1  
 SCSI IN cable, installation, formatter, discussed 2-25  
 SCSI OUT cable, installation, formatter, discussed 2-25  
 Shield bracket, installation, discussed 2-12  
 Shield bracket, tape drive, illustrated 2-12  
 Shielding clamp, installation, discussed 2-8  
 Shipping claims, reporting 2-3  
 Software, Convex OS configuration, discussed 3-1  
 Software integration, tape system, discussed 3-1  
 Specifications, ACL, discussed B-1  
 Specifications, cartridge tape, chart 1-6  
 Specifications, formatter, chart 1-7  
 Stabilizer bars, expansion cabinet, illustrated 2-6, 4-3, C-5  
 Storage capacity, discussed 1-1  
 Strain relief, cable shielding clamp, illustrated 2-8, 2-10, 2-11  
 Strain relief, cable shielding clamp, installation, discussed 2-8  
 SW1, dip switch, configuration, formatter, chart 2-21  
 SW2, dip switch, configuration, formatter, chart 2-21  
 Switch, C200 Series front panel power control, illustrated C-3  
 Switch, front panel power control, illustrated 2-4  
 Switch, SW1, configuration, formatter, chart 2-21  
 Switch, SW2, configuration, formatter, chart 2-21  
 Switches, DI card, formatter configuration, discussed 2-19  
 Switches, DI card, formatter, illustrated 2-19  
 System configuration, discussed 1-1  
 System configuration, expansion cabinet, discussed 2-2  
 System diagram, illustrated 1-1  
 System installation, ACL, discussed B-1, C-1  
 System installation, cartridge tape, discussed 2-3

---

**T**

---

TAC xii  
 Tape, cartridge, depth, chart 1-6  
 Tape, cartridge, height, chart 1-6  
 Tape, cartridge, humidity change, chart 1-6  
 Tape, cartridge, humidity range, chart 1-6  
 Tape, cartridge, illustrated 1-3  
 Tape, cartridge, noise, chart 1-6  
 Tape, cartridge, operating altitude, chart 1-6  
 Tape, cartridge, overview, discussed 1-3  
 Tape, cartridge, specifications, chart 1-6  
 Tape, cartridge, temperature change, chart 1-6  
 Tape, cartridge, temperature range, chart 1-6  
 Tape, cartridge, voltage, chart 1-6  
 Tape, cartridge, weight, chart 1-6

Tape, cartridge, width, chart 1-6  
 Tape drive, air filter, removal/replacement, discussed 4-6  
 Tape drive, cabling, discussed 2-14  
 Tape drive cabling, illustrated 2-14  
 Tape drive, cleaning, discussed 4-1  
 Tape drive, CR board, removal/replacement, discussed 4-6  
 Tape drive, DC power cable, illustrated 2-12  
 Tape drive, DC power cable, installation, discussed 2-12  
 Tape drive, filter maintenance, discussed 4-2  
 Tape drive, formatter, cabling, illustrated 2-23  
 Tape drive, installation, discussed 2-8  
 Tape drive, internal tests, discussed 3-3  
 Tape drive, OP panel, removal/replacement, discussed 4-6  
 Tape drive, parts list, chart 4-9  
 Tape drive, removal/replacement, discussed 4-2  
 Tape drive, shield bracket, illustrated 2-12  
 Tape drive, vane pump filter, removal/replacement, discussed 4-6  
 Tape drives, daisy chain cabling, discussed 2-14  
 Tape system, cable IPB, illustrated 4-11  
 Tape system, cable list, chart 4-10  
 Tape system, *dev\_v8480* diagnostic, discussed 3-3  
 Tape system, software integration, discussed 3-1  
 technical assistance xii  
 Technical Assistance Center xii  
 Temperature change, cartridge tape, chart 1-6  
 Temperature change, formatter, chart 1-7  
 Temperature range, cartridge tape, chart 1-6  
 Temperature range, formatter, chart 1-7  
 Terminator, formatter, discussed 2-25  
 Tests, internal, formatter, discussed 3-4  
 Tests, internal, tape drive, discussed 3-3  
 Tool, PC board removal, formatter, discussed 4-8  
 Transfer rate, discussed 1-1

---

**U**

---

Unpacking, inspection, discussed 2-1  
 Unpacking system, discussed 2-3

---

**V**

---

Vane pump filter, tape drive, removal/replacement, discussed 4-6  
 Voltage, cartridge tape, chart 1-6  
 Voltage jumper, power supply, formatter, discussed 2-17  
 Voltage jumper, power supply, formatter, illustrated 2-17  
 Voltage range, formatter, chart 1-7

---

**W**

---

Warnings, described x  
 Weight, cartridge tape, chart 1-6  
 Weight, formatter, chart 1-7  
 Width, cartridge tape, chart 1-6  
 Width, formatter, chart 1-7

